

AIRQ SCOUT-LCD

Intrinsically Safe Gas Monitor with Wireless Telemetry

900 MHZ WIRELESS WITH 0.5 MILE (800 M) RANGE

CONTINUOUS OR SCHEDULED MEASUREMENT

LOW MAINTENANCE SMART GAS SENSOR

BATTERY POWERED

CLASS I DIVISION 1 CERTIFIED

SUITABLE FOR MEASURING: H2S, CO2, LEL



PRODUCT DESCRIPTION

The AirQ Scout-LCD is a modular wireless gas detection platform with integrated 900 MHz wireless communications. It continuously monitors gas concentration at the point of risk and transmits measurements wirelessly to a SignalFire Gateway or RANGER900 for integration into SCADA, DCS, or cloud systems.

The smart gas sensor is powered from the built-in 72 A/h battery pack and uses embedded signal processing to deliver stable, accurate readings with long-term stability and predictive diagnostics. It automatically compensates for temperature, communicates digitally with the transmitter, and stores calibration data and sensor life information internally to minimize field setup and maintenance errors.

A local LCD display, alarm indicators, and sealed keypad enable full field operation - including zero/span calibration, bump tests, and alarm checks - without laptops, handheld programmers, or special magnetic tools, allowing fast service in Class I Division 1 environments. In addition, two bright red LED lights provide for local alarm notification whenever the gas exceeds a threshold.

FEATURES

- Integrated smart gas sensor with internal diagnostics and stored calibration data
- Local LCD with visual indication of gas level, sensor status, and remaining sensor life
- Integrated keypad for zero and span calibration, bump testing, and alarm checks - no laptop or handheld required
- 900 MHz license-free ISM band radio with 0.5 mile (800 m) line-of-sight range
- Continuous or scheduled (emissions) measurement modes with fast sensor sampling
- Reports gas concentration plus sensor health and fault conditions to the supervisory system
- Long-life 72 A/h Class I Division 1 battery pack, field replaceable
- IP65 industrial polycarbonate housing with integrated, protected antenna
- Class I Division 1 certified (pending), Groups C, D, T4 (hazardous locations)

AIRQ SCOUT-LCD

Intrinsically Safe Gas Monitor with Wireless Telemetry

GAS SENSOR SPECIFICATIONS

Table 1

Gas Sensor	Specifications	Details
H2S	Technology:	Electrochemical
	Detection Method:	Diffusion
	Sensitivity:	0-100ppm (1ppm MDL)
	Accuracy:	+/- 2% of full scale
	Zero Baseline Shift:	<1% of full scale
	Span Drift:	<2% signal loss per year
	Temperature Range:	-40°F to 131°F (-40°C to +55°C)
	Humidity:	15% to 95% non condensing
Pressure Range:	1 atmosphere +/- 0.1 atm	

MEASUREMENT MODES

Table 2

Sensor	Measurement Mode	Sensor Power & Measurement Frequency	Values Reported
H2S	Continuous	Sensor continuously powered. Values reported every 5 min (configurable) or by exception.	PPM Atmospheric Pressure Ambient Temperature Relative Humidity Absolute Humidity

AIRQ SCOUT-LCD

Intrinsically Safe Gas Monitor with Wireless Telemetry

TECHNICAL SPECIFICATIONS

Table 3

Physical Specifications	
Dimensions	8" x 7" x 4" (20cm x 18cm x 10cm)
Weight	2 Lbs (0.9Kg)
Housing Material	Industrial polycarbonate UV rated
Enclosure Protection	IP65
Mechanical installation	Flange mount
Electrical Specifications	
Input Power	Integrated Battery: 72A/h four (4) D cell lithium battery pack. Field replaceable. Solar (optional): Sentinel HC-Solar System , C1D1 with integrated rechargeable battery
Battery Life	24 months: Continuous Gas Sampling, 5-minute reporting to Gateway
Environmental	
Ambient Operating Temperature	-40 to +131°F (-40°C to +55°C)
Humidity	0% - 99% non-condensing
Local Interface	
Transflective Display	High resolution graphic display with backlight (can operate down to 0°F (-20°C)
Local Keypad	5 Button Keypad for local diagnostics, bump tests, and calibration
Alert Notification	Bright red LEDs, blink when gas exceeds alarm threshold
Clock	Real-Time Clock , stores calibration events. CR2032 coin cell battery included to maintain time.
Local Computer Configuration	USB-C port, requires SignalFire Toolkit Software
Communications	
Data Transmission	Report interval 5 seconds to 2 hours Configurable measurement threshold to report on exception.
Data Interface	Requires a SignalFire Gateway. Gateways support Modbus RTU, Modbus-TCP, EtherNet/IP, MQTT/Sparkplug
RF Radio Power	40mW, Receive Sensitivity -109dB
RF Distance	0.5 mile (800 meters)
RF Band	902–928 MHz, FHSS, license-free ISM Band
Antenna	Internal omni-directional Antenna
Cloud Connectivity / Monitoring	SignalFire Cloud connectivity via RANGER900 or PATRIoT Gateway
Gas Sensor	
H2S	See table for gas sensor specifications
CO2	Pending. See table for gas sensor specifications
LEL	Pending. See table for gas sensor specifications
Gas Sensor Diagnostics	
Sensor Life	Gas sensor reports remaining life in increments of 25%
Sensor Data	Sensor Calibration data and date stored in sensor module
Sensor Fault Reporting	Missing Sensor, VDC Fault, Over Range, Under Range

AIRQ SCOUT-LCD

Intrinsically Safe Gas Monitor with Wireless Telemetry

TECHNICAL SPECIFICATIONS

Table 3

Approvals	
Hazardous locations (<i>pending</i>)	Class 1 Division 1 Certified, Groups C & D. Temperature Code T4 Certified to CSA C22.2 No. 213:2017, Conforms to UL 121201:2017
ISM Band	Compliant with FCC Part 15, IC (Industry Canada)
FCC ID	Pending
IC ID	Pending
Accessories	
4DPAK battery	72A/h battery pack with super capacitor
Sentinel HC-Solar System	High Capacity Intrinsically Safe Solar System, 9.0AH Capacity

DIMENSIONS

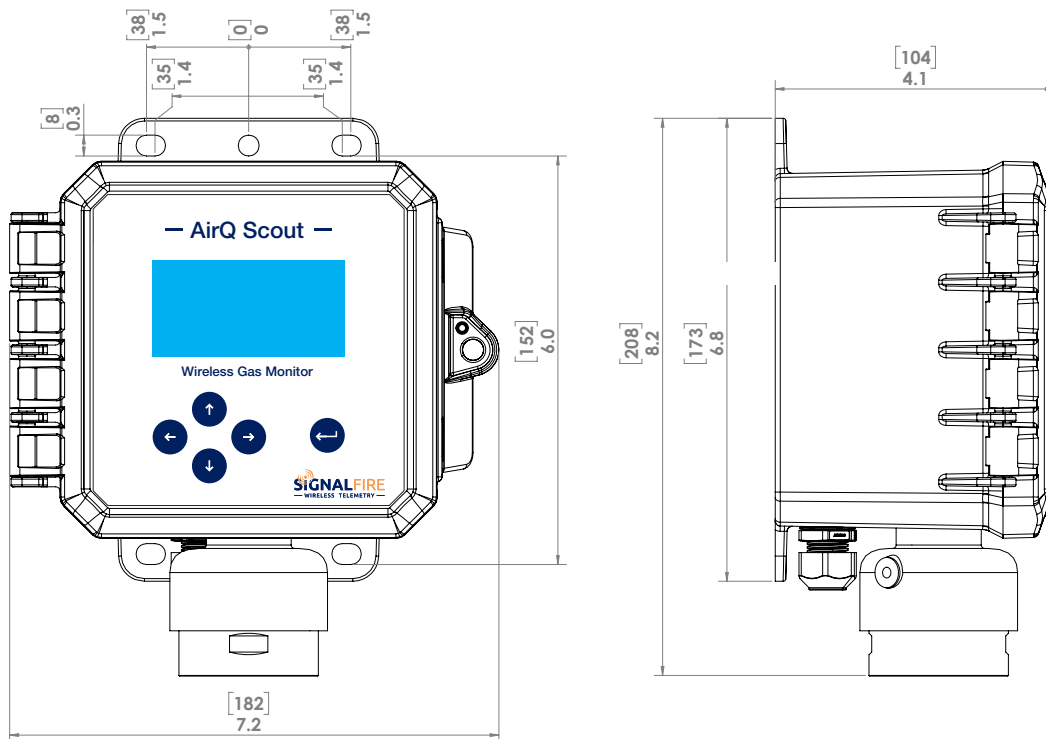

AIRQ SCOUT-LCD

Intrinsically Safe Gas Monitor with Wireless Telemetry

HOW TO ORDER

AIRQ SCOUT WITH SIGNALFIRE 900MHZ RADIO

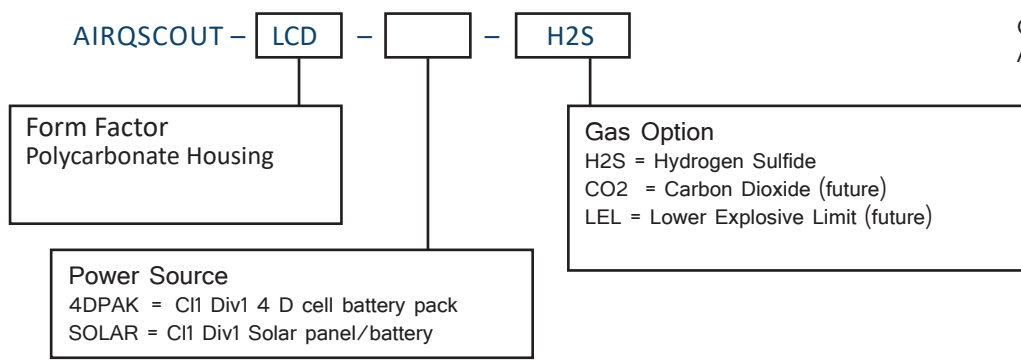

Order Code Example:
AIRQSCOUT-LCD-4DPAK-H2S