

AirQ Scout-LCD Manual



Specifications

Overall Size	8"x7"x4"
Power Source	Internal (4) D cell 72A/h Battery Pack. Field replaceable. Solar: Sentinel-HCSolar system
Temperature Rating	$-40^{\circ}\text{C} \leq T_{\text{amb}} \leq +55^{\circ}\text{C}$ (-40°F to 131°F)
Radio Frequency	902-928MHz ISM Band, FHSS radio, internal antenna FCC ID: Pending IC: Pending
H2S Sensor	Sensor Range: 0-100ppm Sensor Technology: Electrochemical Response Time : T90 less than 60s Accuracy : $\pm 2\%$ of full scale Zero Baseline Shift : $< 1\%$ of full scale (-30°C to +50°C) Span Drift: $< 2\%$ signal loss per year
Compliance & Hazardous Area Approvals	Class 1 Division 1, Temp Code T3, Groups C&D. - pending
Battery Life	24 months: Continuous Gas Sampling, 5-minute reporting to Gateway
Radio Power	40mW, Receive Sensitivity -109dB
Range	0.5 Miles (800 meters)

Table of Contents

Specifications.....	2
Table of Contents.....	3
Connections and Components	5
Operation	5
Main Menu Navigation.....	6
Smart Gas Sensor	6
Smart Sensor Benefits.....	7
Calibration and Sensor Data.....	7
Sensor Status Monitoring.....	7
Sensor Replacement.....	7
Setup.....	10
Using the SignalFire Toolkit.....	10
Network Setting	12
Modbus ID.....	12
Calibration (Zero & Span).....	13
Overview.....	13
<i>Recommended calibration and bump test interval</i>	13
<i>Calibration gas requirement</i>	13
<i>Safety and handling notes</i>	13
Navigation (LCD).....	14
Zero calibration	14
Span calibration (50 ppm H ₂ S)	15
<i>Viewing calibration records (Calibration Info)</i>	16
Bump Test.....	17
<i>Pass criteria and test gas selection</i>	17
Procedure	17
Offline Mode.....	18
Remote Modbus Register Mapping.....	19
Modbus Registers.....	19
Register Map.....	19
Mounting and Care	20
Internal Lithium Battery Replacement.....	21

Cleaning Instructions 21

Configuration / Debug 21

Disposal 21

 Lithium Primary Battery:..... 21

 Electronic Components:..... 21

 Metal Parts: 21

 Packaging Materials: 22

Technical Support And Contact Information..... 25

Connections and Components

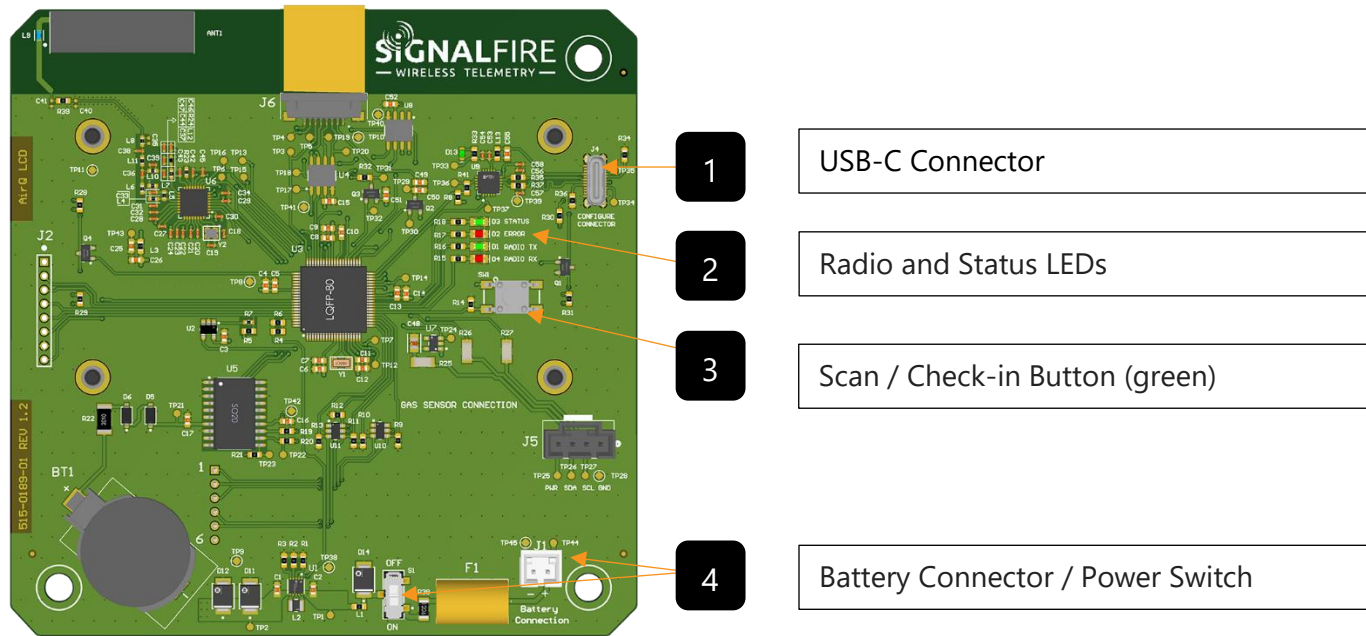

Radio LEDs

- The Radio TX LED (**green**) blinks each time a radio packet is sent. This LED will blink rapidly while searching for the radio network and at boot up.
- The Radio RX LED (**red**) blinks on each received radio packet.

Status LEDs

- The STATUS LED (**green**) will blink on when the AirQ Scout-LCD sends a message to the Gateway.
- The ERROR LED (**red**) will blink to indicate an error condition.

Scan/Check-in Button

- If this button is pressed the AirQ Scout-LCD will take a reading from the sensor and send the data to the gateway.

Operation

The Gas Sensor is continuously powered and sampled once a second. Values are updated on the LCD in real time and are reported every check-in interval or immediately if the detected gas level exceeds the configured alarm threshold (10ppm by default).

When the gas concentration is above the alarm threshold, the red alarm LEDs on the AirQ Scout-LCD will flash and the LCD will indicate an alarm condition. While in alarm the AirQ Scout-LCD will report its values to the Gateway every 5 seconds until the concentration goes below the threshold.

Main Menu Navigation

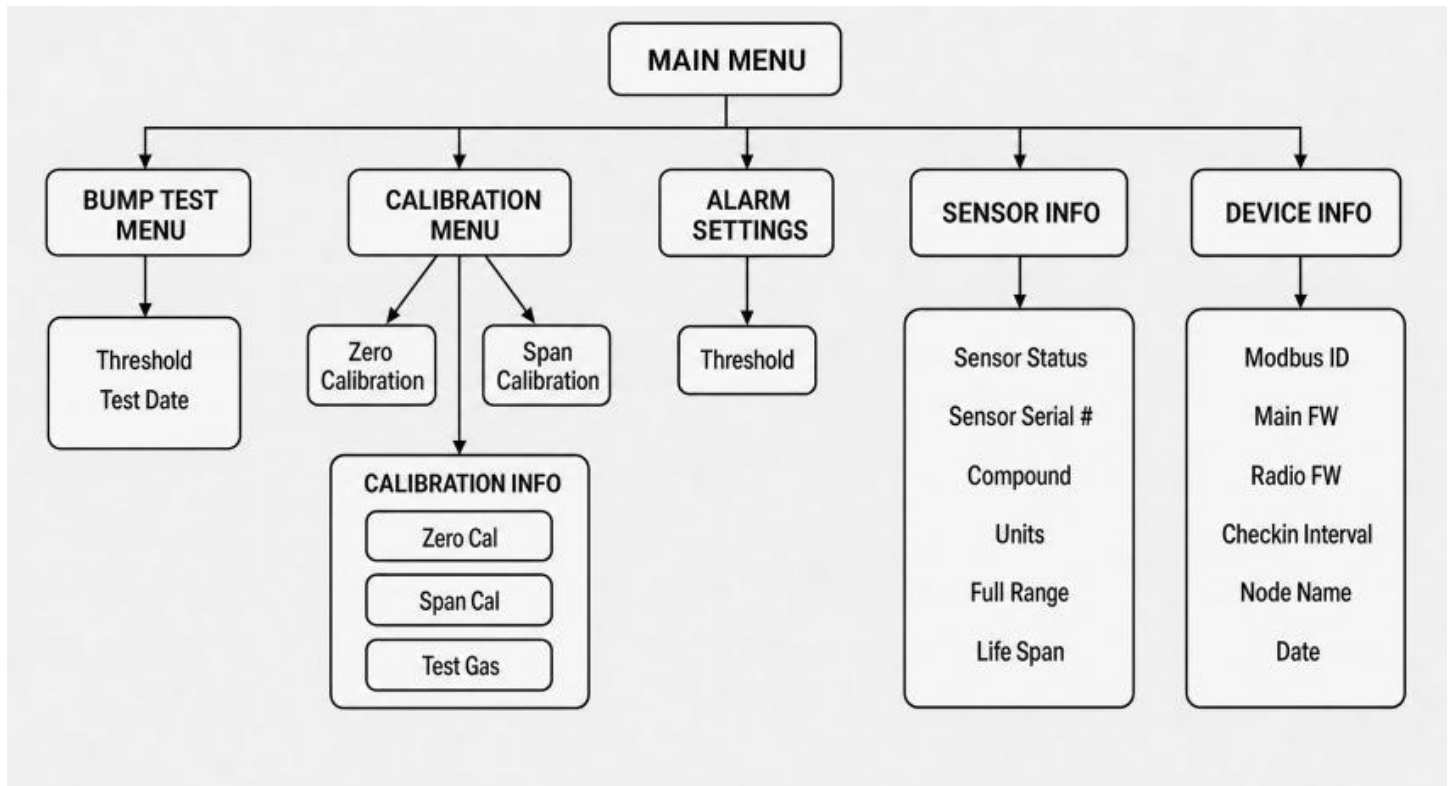

The LCD display can show users measurement data, sensor diagnostics, calibration history, and more. Enter the “Main Menu” from the measurement screen by pressing the enter button once. Use the arrow navigation and enter key(s) to select and enter a submenu. Use the left arrow key to back out of a submenu.

Smart Gas Sensor

The AirQ Scout-LCD utilizes an integrated smart hydrogen sulfide (H₂S) gas sensor designed for continuous industrial gas monitoring applications. The sensor combines an electrochemical sensing element with onboard digital signal processing to provide accurate, stable, and reliable gas concentration measurements.

The sensor operates as a fully digital device and communicates measurement data, calibration information, and diagnostic status directly to the AirQ Scout-LCD electronics.

Sensor Description

The smart H₂S sensor integrates:

- An electrochemical hydrogen sulfide sensing element
- Onboard microprocessor-based signal conditioning
- Embedded temperature compensation and detection analytics

All critical sensor parameters are stored internally within the sensor and automatically reported to the AirQ Scout-LCD during operation.

Upon power-up, the sensor provides the AirQ Scout-LCD with its gas type, measurement range, calibration data, and sensor status, enabling automatic configuration and startup without user intervention.

Smart Sensor Benefits

The smart sensor architecture provides several advantages over traditional analog gas sensors:

- Internal data storage
Calibration coefficients, sensor range, gas type, and sensor life data are stored within the sensor itself.
- Temperature compensation
Embedded temperature compensation improves measurement accuracy across the full operating temperature range.
- Digital signal integrity
Digital communication between the sensor and the AirQ Scout-LCD eliminates analog signal drift and improves long-term measurement stability.
- Integrated diagnostics
Sensor health, operating state, and fault conditions are continuously monitored and reported. Sensor life is updated in 25% increments (100, 75, 50, 25, 0) and can be used for trending and proactive maintenance planning.

Calibration and Sensor Data

Calibration data is stored within the smart sensor, not in the AirQ Scout-LCD. This ensures calibration information is retained even if the sensor is removed or replaced.

The following calibration and maintenance data are maintained by the sensor and made available to the AirQ Scout-LCD:

- Last zero calibration date
- Last span calibration date
- Sensor life remaining (%)

Sensor Status Monitoring

The AirQ Scout-LCD continuously monitors sensor operating status and reports sensor conditions through the LCD, wireless gateway, and Modbus registers. Sensor status indications include:

- Normal operation
- Warm-up
- Calibration in progress
- Over-range or under-range conditions
- Sensor fault or missing sensor

These diagnostics allow early detection of sensor issues and help ensure reliable gas monitoring performance.

Sensor Replacement

The smart H₂S sensor module is field replaceable. Replacement sensors must be obtained from SignalFire Telemetry and must match the required gas type and measurement range.

Use of unapproved sensors may result in incorrect readings, loss of diagnostic functionality, or degradation of system performance.

Procedure:

IMPORTANT: Power the unit off prior to replacing the sensor

1. When it is safe to do so, locate the smart sensor module on the bottom of the enclosure.
2. Gently grip the lower section of the smart sensor module and turn it counterclockwise to remove it (the lower section has two flats 180° apart to make this process simpler).



3. Once the lower section of the smart sensor module has been removed, the actual sensor will be exposed.



4. Gently grip the sensor and slowly pull on it until it comes out. The sensor is secured into place with 4 pins. Do not try to rotate the sensor.



5. Install the new sensor by carefully aligning the four pins of the sensor with the four holes on the enclosure.

Setup

The AirQ Scout-LCD needs to be set up for correct operation before being installed. The configurable items include:

- Network selection
- Check-in period selection
- Modbus Server ID setting
- Optional alarm thresholds

All settings are made using the SignalFire Toolkit PC application and a USB-C cable

Using the SignalFire Toolkit

The SignalFire Toolkit application can be downloaded at <https://www.signal-fire.com/signalfire-toolkit-software/>. After installation, launch the software and the main toolkit window will open:

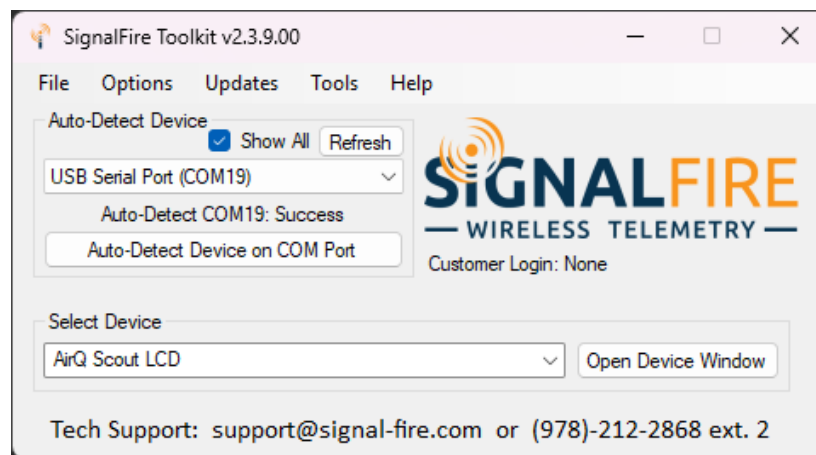

Select the COM port associated with the AirQ Scout-LCD and click "Auto-Detect Device on COM Port." This will open the device configuration window, where all device settings can be configured.

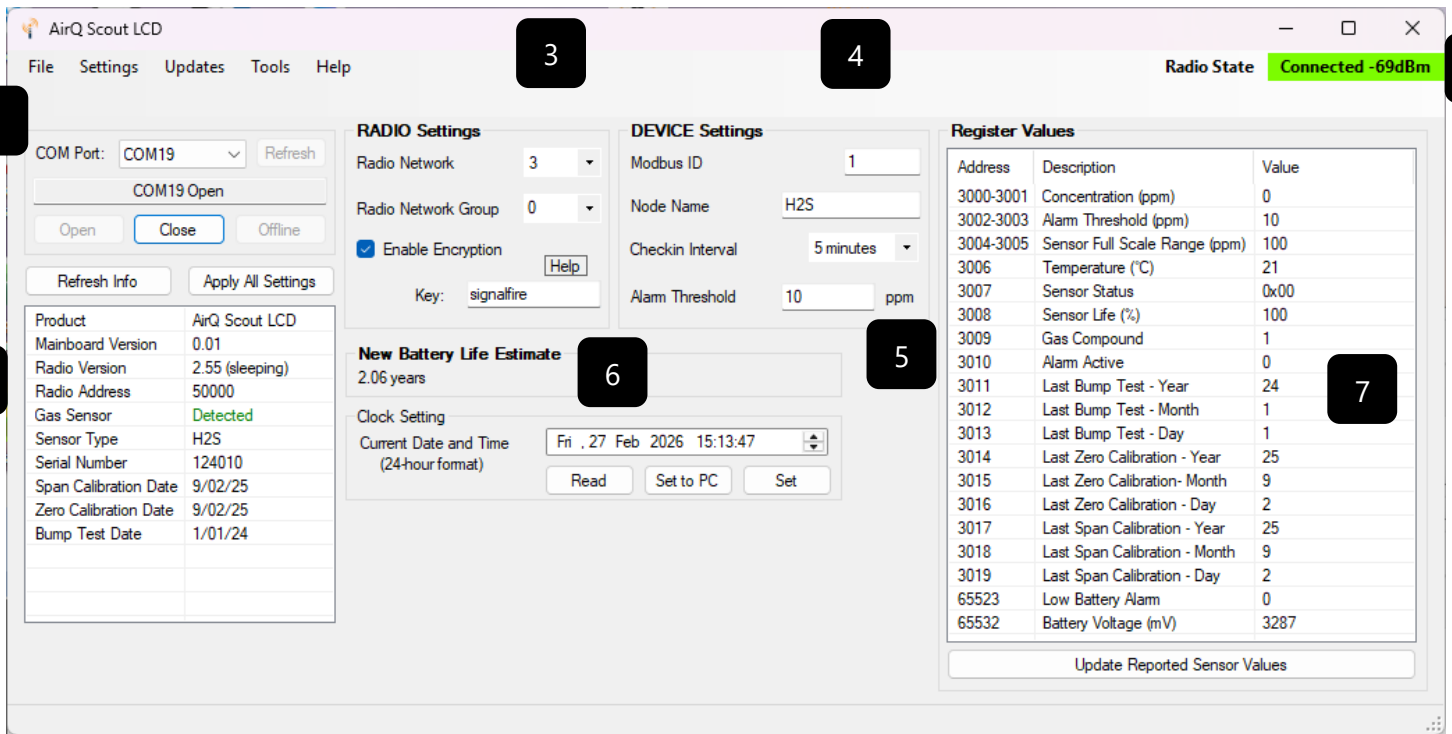

1	Serial Port Settings	2	Scout Information
3	Radio Settings	4	Node Device Settings
5	Alarm Threshold Settings	6	Battery Life Estimate
7	Modbus Register Values	8	Connection Status

Network Setting

The network is set using the SignalFire Toolkit. The network, network group, and corporate ID/encryption key **settings must match those of the gateway for them to communicate**. When any setting is changed, it will be highlighted yellow, indicating it has not actually been written to memory. To apply the desired settings, click the **Apply All Settings** button in the upper left-hand corner.

Encryption

To protect your over-the-air data and prevent tampering, SignalFire networks come with encryption.

To set up a AirQScout-LCD to use encryption, click the checkbox labeled **Enable Encryption** inside the **Set Corporate ID** box. All new AirQScout-LCD units come with this option enabled with "signalfire" as the default encryption key.

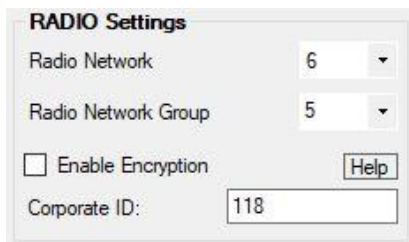

The screenshot shows the 'RADIO Settings' dialog box. It contains two dropdown menus: 'Radio Network' set to 6 and 'Radio Network Group' set to 5. Below these is a checkbox labeled 'Enable Encryption' which is currently unchecked. To the right of the checkbox is a 'Help' button. At the bottom, there is a text input field labeled 'Corporate ID' containing the value '118'.

Corporate ID

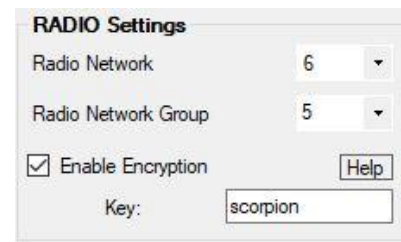

The screenshot shows the 'RADIO Settings' dialog box. It contains two dropdown menus: 'Radio Network' set to 6 and 'Radio Network Group' set to 5. Below these is a checkbox labeled 'Enable Encryption' which is currently checked. To the right of the checkbox is a 'Help' button. Below the checkbox is a text input field labeled 'Key' containing the value 'scorpion'.

Encryption Enabled

The box will then change into a **Set Encryption Key** box, and it will prompt instead for the encryption key you would like to use. Note that keys may not contain spaces or angle brackets. If you are setting up a new network, you will need to set the encryption key on all your devices. If you are adding an AirQ Scout to a legacy network, you can simply set the Corporate ID without clicking the Enable Encryption box, and it will remain compatible with the older system.

It is also possible to hide your encryption key so it cannot be read. This is the most secure option, but if you forget your key, there is no way to recover it – you must reset the key on every device on the network. To enable this option, select **Set Encryption Key Unrecoverable** under the **Settings** menu.

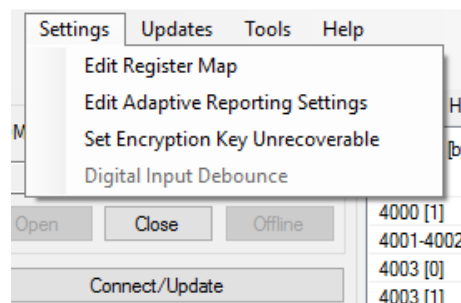

Setting the encryption key to be unrecoverable.

Modbus ID

The Modbus ID can be set with the SignalFire Toolkit. Each remote device connected to the gateway must have a unique Modbus ID (1-240). Every SignalFire device must have a unique ID to prevent conflicts.

Alarm Threshold Settings

When the gas concentration is above the alarm threshold, the red alarm LEDs on the AirQ Scout-LCD will flash and the LCD will indicate an alarm condition. While in alarm the AirQ Scout-LCD will report its values to the Gateway every 5 seconds until the concentration goes below the threshold.

The alarm threshold can be adjusted using the SignalFire ToolKit or from the Alarm Threshold menu on the LCD screen

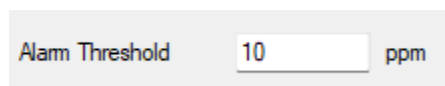

Setting the alarm thresholds.

Calibration (Zero & Span)

Overview

Gas sensors drift over time due to normal aging and exposure. Calibration is the process used to establish a correct baseline (zero) and adjust the sensor response to a known gas concentration (span). This is different from a bump test, which is a quick functional check that confirms the sensor responds to gas and alarms activate; calibration is intended to confirm and adjust measurement accuracy.

The AirQ Scout-LCD uses a smart gas sensor that stores calibration offsets and calibration dates in the sensor itself.

Recommended calibration and bump test interval

Electrochemical H₂S sensing technology requires periodic user interaction to confirm proper operation and correct for sensor drift. A recommended maximum interval is 6 months for zero/span calibration and bump testing. More frequent calibrations may be performed at the user's discretion, especially if unusual drift is observed for the installation environment.

Sensor life is also updated and reported in 25% increments: 100, 75, 50, 25, 0. These values may be collected over time to help track the sensor's life cycle and plan preventative sensor replacement based on operating environment and exposure conditions.

Calibration gas requirement

Span calibration for this device is based on 50 ppm H₂S calibration gas. The calibration information screen displays the configured test gas value.

Safety and handling notes

Hydrogen sulfide is toxic. Perform calibration in a well-ventilated area and route the calibration gas outlet away from the breathing zone. Use appropriate PPE and follow your site safety procedures.

If you cannot verify that the surrounding air is free of H₂S (and other interfering gases), use a clean air source intended for zeroing rather than ambient air.

Typical items used for zero/span calibration include:

- Certified 50 ppm H₂S calibration gas cylinder
- Compatible regulator and tubing
- A calibration adapter/cap or suitable method to apply gas to the sensor inlet

Navigation (LCD)

From the device Main Menu, access calibration using the on device keypad:

- Main Menu screen

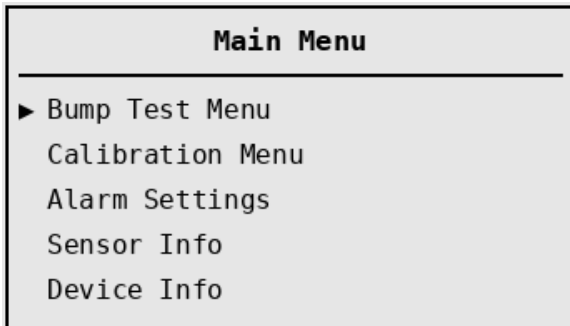

- Select "Calibration Menu" to open the Calibration Menu screen

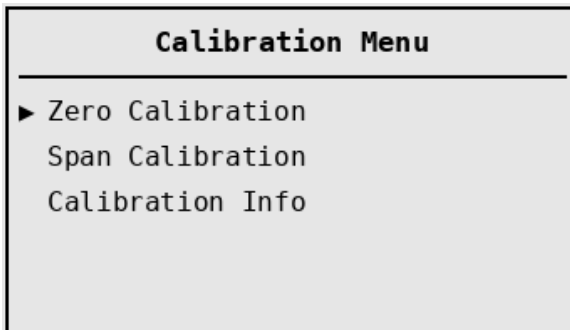

- The Calibration Menu includes: "Zero Calibration", "Span Calibration", and "Calibration Info"

Zero calibration

Purpose

Zero calibration establishes the baseline reading in air that is known to be free of the target gas. This step is used to correct baseline offset so the device reads near zero in clean air.

Procedure

1. Ensure the sensor is in clean air and the reading is stable. If clean air cannot be confirmed, use a verified zero-air source.
2. From the Calibration Menu, highlight and select "Zero Calibration" and press the Enter button

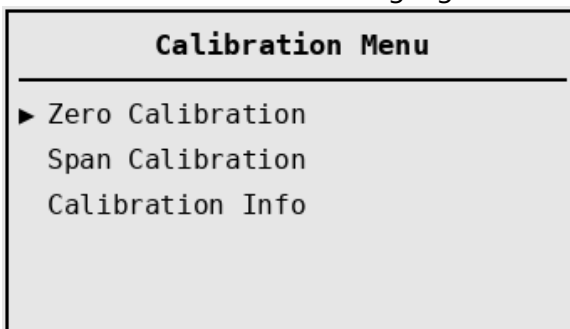

3. The LCD prompts: "Start Zero Cal?" with options "Cancel" and "Okay". Select "Okay" to begin.

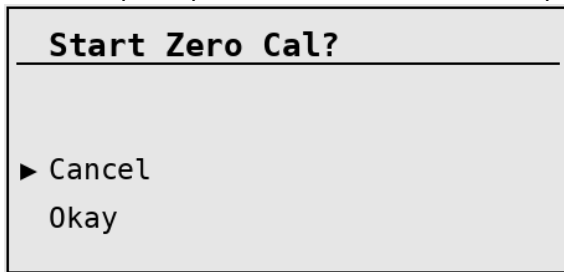

4. Allow the device to complete the zero calibration sequence.
5. After completion, verify the recorded date using "Calibration Info". Calibration date information is maintained by the sensor.

Calibration Info	
Zero Cal	1/15/26
Span Cal	2/22/26
Test Gas	50ppm

Span calibration (50 ppm H₂S)

Purpose

Span calibration adjusts the sensor response so the displayed reading matches a known, traceable concentration of test gas. This compensates for sensor sensitivity changes over time

Procedure

1. Confirm you have the correct test gas: 50 ppm H₂S, and confirm the cylinder is within its expiration date.
2. Assemble the regulator, tubing, and calibration adapter/cap so gas is applied properly to the sensor.
3. From the Calibration Menu, highlight and select "Span Calibration", and press the Enter button

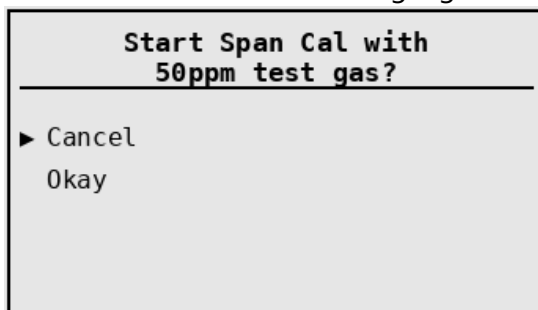

4. Apply the test gas to the sensor and allow the reading to stabilize during the calibration routine (allow roughly 90 seconds for reading to stabilize).

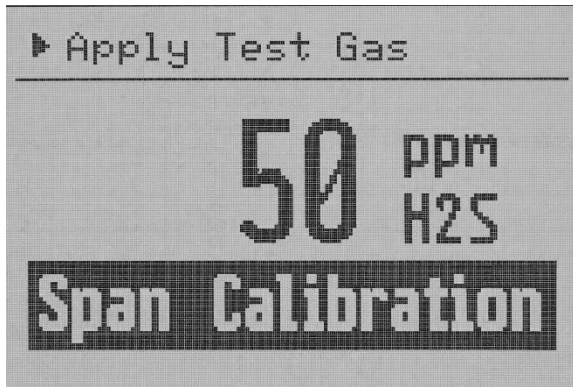

- Once the reading has stabilized, the LCD display will flash once to alert the user to remove test gas.

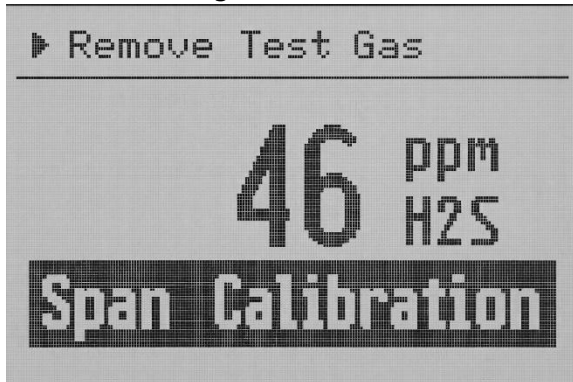

- After the test gas is removed, the display will show that the calibration is complete and indicate whether or not the calibration was successful.

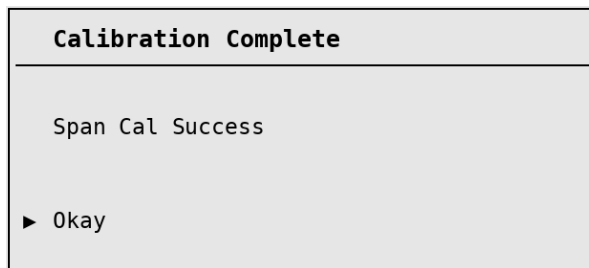

- When complete, verify the recorded span calibration date and test gas value in "Calibration Info". Calibration data is stored in the smart sensor and includes calibration date tracking.

Calibration Info	
Zero Cal	1/15/26
Span Cal	2/22/26
Test Gas	50ppm

Viewing calibration records (Calibration Info)

Use "Calibration Info" to view the most recent calibration dates and configured test gas value. This screen shows:

- Zero Cal (date)
- Span Cal (date)
- Test Gas (50 ppm)

In addition to the LCD, calibration and bump test dates are available through the gateway Modbus mapping as separate year/month/day registers for the last bump test, last zero calibration, and last span calibration.

Bump Test

A bump test is a quick functional check used to confirm that the AirQ Scout-LCD responds to H2S and enters an alarm condition when exposed to test gas. Unlike calibration, a bump test does not adjust accuracy; it verifies basic sensor response and alarm operation.

Pass criteria and test gas selection

The bump test is implemented as an alarm-based check. For the bump test to pass, the applied H2S concentration must rise above the configured alarm threshold. Because of this, you must use test gas with a concentration higher than the current alarm threshold setting.

The alarm threshold is configurable, and the AirQ Scout-LCD will enter alarm and indicate an alarm condition when the measured concentration exceeds the configured threshold (10 ppm by default)

Procedure

1. Ensure the AirQ Scout-LCD is operating normally and the reading is stable in clean air.
2. Open the Bump Test Menu

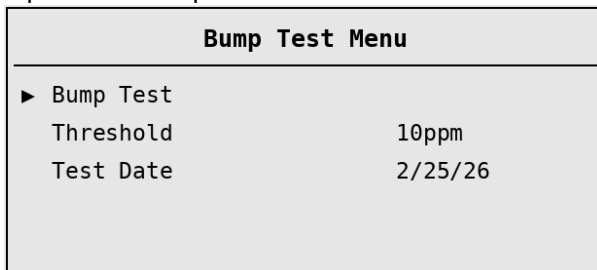

3. Select Bump Test. The LCD will prompt "Start Bump Test?", Select Okay to begin.

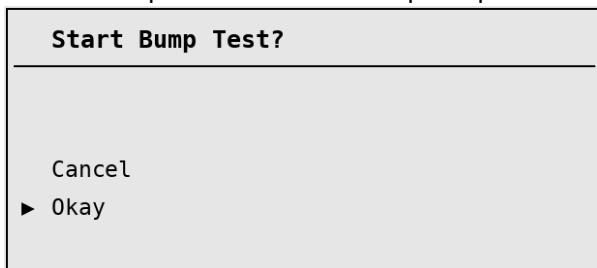

4. When prompted to apply gas apply H2S test gas using the calibration adapter/cap and tubing. Use a concentration that is higher than the configured alarm threshold so the unit can enter alarm and register a pass.

5. Maintain gas flow until the bump test completes and a result is displayed:

- Pass example: "Bump Test Complete / Bump Test Pass"

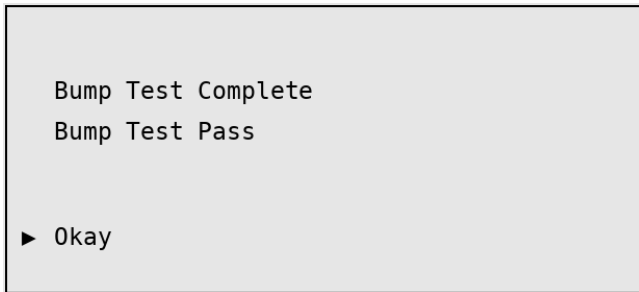

- Fail example: "Bump Test Failed / Bump Test Timeout"

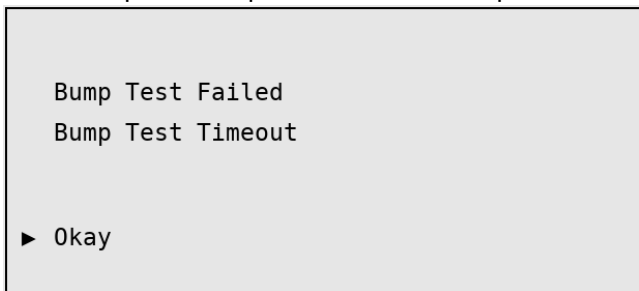

6. Close the regulator valve and remove the calibration adapter/cap. Allow the reading to return to normal.

Notes

- **If the alarm threshold has been configured above the available test gas concentration, the AirQ Scout-LCD may not enter alarm during the bump test and can fail even when the sensor is functioning. In this case, use higher concentration test gas or adjust the alarm threshold per your site procedure. While the zero and span calibration dates are stored in the sensor, the last successful bump test date is stored in the AirQ device itself. All dates are viewable on the LCD screen or via Modbus registers.**

Offline Mode

Offline Mode is implemented as a battery saving feature for cases when the AirQ Scout is unable to communicate with a Gateway. If the configured check-in interval is less than 15-minutes, and the AirQ Scout cannot contact a Gateway for two consecutive hours it will enter "offline mode". In offline mode the Scout will back off and only attempt to scan for the gateway every 15-minutes. This means that once a Scout enters offline mode, it will take it up to 15-minutes for the Scout to reconnect to a Gateway when the communication issue is resolved.

Examples that would cause a Scout to enter offline mode:

- AirQ Scout is powered on more than two hours before the Gateway is installed
- Gateway loses power

Remote Modbus Register Mapping

The AirQ Scout-LCD sends data to a SignalFire Telemetry Gateway. The data that is sent to the gateway is available at the gateway in registers where it can then be read by a Modbus RTU. Consequently, the node needs to have a unique (to the network it is in) Modbus ID which the gateway will use to store its unique data.

Modbus Registers

Every check-in period, the sensors are read and data is sent to the gateway. The gateway will save the data under the set Modbus ID in 16-bit registers. The register map for this system is below.

Register Map

Register Number	Register Address (Offset)	Description	Datatype
43001-43002	3000-3001	Concentration (ppm)	FLOAT
43003-43004	3002-3003	Alarm Threshold (ppm)	FLOAT
43005-43006	3004-3005	Sensor Full Scale Ranger (ppm)	FLOAT
43007	3006	Sensor Temperature (°C)	INT16
43008	3007	Sensor Status	INT16
43009	3008	Sensor Life Remaining (%)	INT16
43010	3009	Sensor Gas Compound	INT16
43011	3010	Alarm Active (0=No Alarm, 1=Alarm Active)	INT16
43012	3011	Last Bump Test - Year	INT16
43013	3012	Last Bump Test - Month	INT16
43014	3013	Last Bump Test - Day	INT16
43015	3014	Last Zero Calibration - Year	INT16
43016	3015	Last Zero Calibration- Month	INT16
43017	3016	Last Zero Calibration - Day	INT16
43018	3017	Last Span Calibration - Year	INT16
43019	3018	Last Span Calibration - Month	INT16
43020	3019	Last Span Calibration - Day	INT16
49987	65523	Low Battery Alarm. 1=Low battery	UINT16
49996	65532	Battery Voltage (mV)	UINT16
49999	65535	Device type (46 for AirQScout-LCD)	UINT16

Sensor Status:

0=Normal, 1=VDC Fault, 2=Cal Fault, 4=Over Range, 8=Missing Sensor, 16=Under Range, 32=Calibration, 64=Warm up, 128=Timeout

Sensor Gas Compound:

0=Unknown, 1=H2S, 2=CO, 3=CO2

Mounting and Care

The AirQ Scout-LCD has a built-in mounting flange. Mount device so that the gas sensor faces downward.

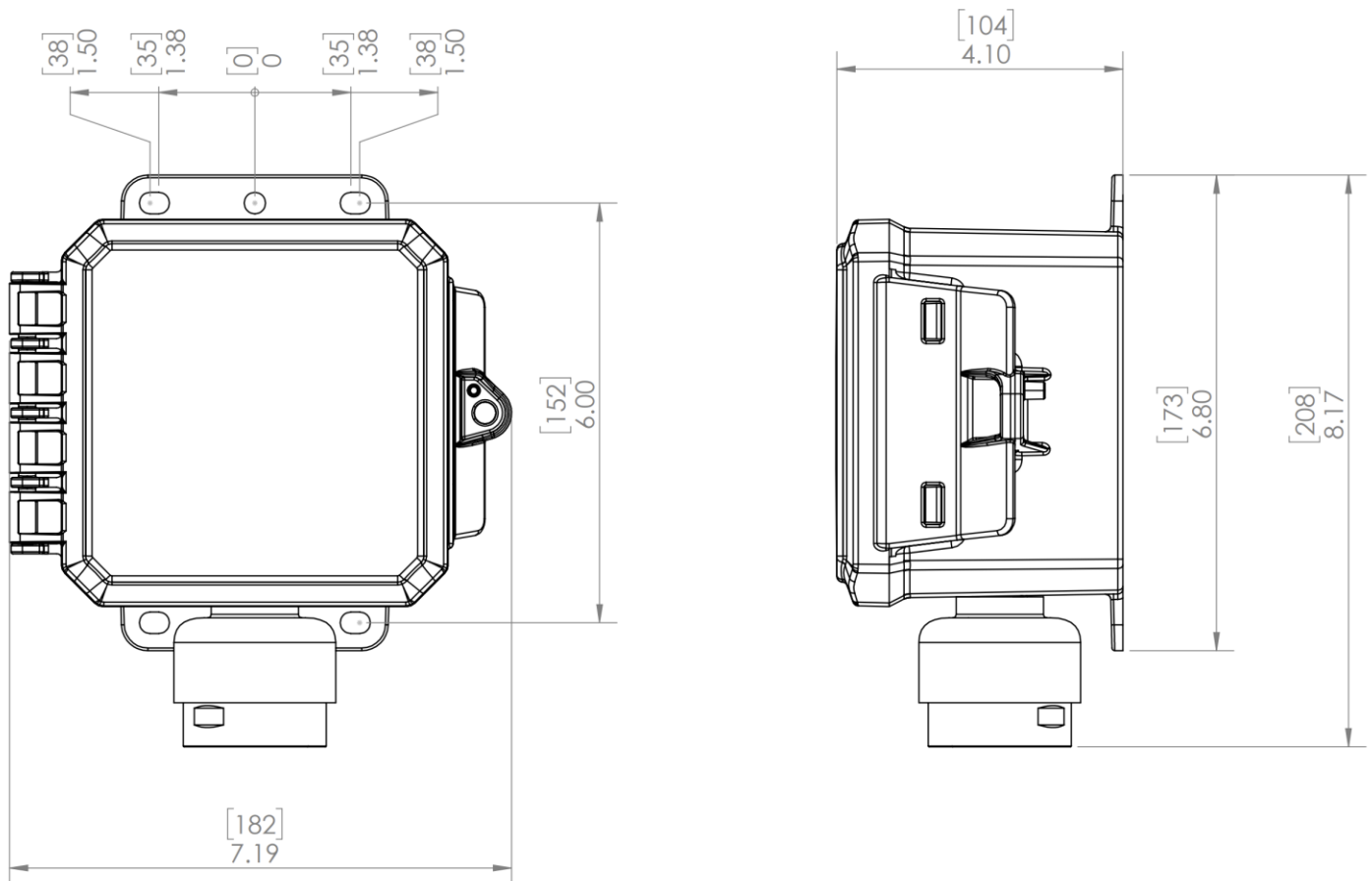

WARNING: The AirQ Scout-LCD must be mounted in a location free of high vibrations. Over time vibrations can damage the device or battery pack, which could impair its safety ratings. Do not mount directly to continuous vibrating equipment such as pumps or compressors.

Internal Lithium Battery Replacement

Battery Packs can be changed with the node in place.

1. Open the cover of the AirQ Scout-LCD
2. Unplug the battery from the PCB, by depressing the locking clip on the connector.
3. Remove the two screws holding the battery strap to the battery bracket
4. Remove/Replace the battery.
5. Reinstall the batter strap and screws
6. Connect the battery to the main PCB battery connector
7. Close the enclosure cover, use care to ensure that the wires are not pinched by the cover.

Cleaning Instructions

The outside of the enclosure may be cleaned with water, mild soap, and a damp cloth as needed. High Pressure washing is not recommended.

Configuration / Debug

Debug and configuration information is available if a connection is made via the debug port on the main board. A USB-C cable must be used for this interface.

Debug and advanced configurations may be done using the SignalFire Toolkit PC application.

Disposal

To ensure environmental safety and compliance, please follow these disposal instructions for the product and its components:

Lithium Primary Battery:

This product contains lithium primary batteries, which must be removed before disposal. Lithium batteries must be recycled through specialized facilities due to their fire risk. Do not place batteries in regular trash.

Electronic Components:

This product contains electronics that must be recycled through approved e-waste recycling programs. Electronics can contain harmful materials and should be prevented from entering landfills. Do not place electronics in regular trash.

Metal Parts:

Any metal components can be separated and recycled through your local metal recycling facility.

Packaging Materials:

Recycle or reuse packaging materials such as cardboard or plastics, following local recycling guidelines.

For local disposal sites refer to:

- [Call2Recycle](#) (USA, Canada)
- [Earth911](#) (USA, Canada)
- [SERI](#) (International)

In the USA or more information, visit:

- [EPA's battery disposal guide](#)
- [EPA's electronics recycling page](#)

By following these guidelines, you help reduce waste and support environmental sustainability.

Revision	Date	Changes/Updates
1.0		Initial release
1.1	4/17/26	Updated menu screen images and circuit board
1.2	5/5/26	Updated image
1.3	5/15/26	Updated cover image and added "Main Menu Navigation" section

APPENDIX - FCC and IC Statements

Changes or modifications not expressly approved by SignalFire Telemetry, Inc could void the user's authority to operate the equipment.

This device complies with Part 15 of the FCC Rules. Operation is subject to the following two conditions: (1) this device may not cause harmful interference, and (2) this device must accept any interference received, including interference that may cause undesired operation.

This equipment has been tested and found to comply with the limits for a Class B digital device, pursuant to Part 15 of the FCC Rules. These limits are designed to provide reasonable protection against harmful interference in a residential installation. This equipment generates, uses and can radiate radio frequency energy and, if not installed and used in accordance with the instructions, may cause harmful interference to radio communications. However, there is no guarantee that interference will not occur in a particular installation. If this equipment does cause harmful interference to radio or television reception, which can be determined by turning the equipment off and on, the user is encouraged to try to correct the interference by one of the following measures:

- Reorient or relocate the receiving antenna.
- Increase the separation between the equipment and receiver.
- Connect the equipment into an outlet on a circuit different from that to which the receiver is connected.
- Consult the dealer or an experienced radio/TV technician for help.

WARNING!

FCC and IC Radiation Exposure Statement:

This equipment complies with FCC's and IC's RF radiation exposure limits set forth for an uncontrolled environment under the following conditions:

1. This equipment should be installed and operated such that a minimum separation distance of 20cm is maintained between the radiator (antenna) & user's/nearby person's body at all times.
2. This transmitter must not be co-located or operating in conjunction with any other antenna or transmitter.

Under Industry Canada regulations, this radio transmitter may only operate using an antenna of a maximum (or lesser) gain approved for this transmitter by Industry Canada. To reduce potential radio interference to other users, the antenna type and its gain should be so chosen that the equivalent isotropically radiated power (e.r.i.p.) is not more than that necessary for successful communication.

Conformément à la réglementation d'Industrie Canada, le présent émetteur radio peut fonctionner avec une antenne d'un type et d'un gain maximal (ou inférieur) approuvé pour l'émetteur par Industrie Canada. Dans le but de réduire les risques de brouillage radioélectrique à l'intention des autres utilisateurs, il faut choisir le type d'antenne et son gain de sorte que la puissance isotrope rayonnée équivalente (p.i.r.e.) ne dépasse pas l'intensité nécessaire à l'établissement d'une communication satisfaisante.

This device complies with Industry Canada licence-exempt RSS standard(s). Operation is subject to the following two conditions: (1) this device may not cause interference, and (2) this device must accept any interference, including interference that may cause undesired operation of the device.

Le présent appareil est conforme aux CNR d'Industrie Canada applicables aux appareils radio exempts de licence. L'exploitation est autorisée aux deux conditions suivantes : (1) l'appareil ne doit pas produire de brouillage, et (2) l'utilisateur de l'appareil doit accepter tout brouillage radioélectrique subi, même si le brouillage est susceptible d'en compromettre le fonctionnement.

Technical Support And Contact Information

SignalFire Telemetry
140 Locke Dr., Suite B
Marlborough, MA 01749

(978) 212-2868
support@signal-fire.com

