

# AirQ Scout Manual

SignalFire Model: AirQScout-STD-4DPak-CH4



## Gas Sensor Specification

Gas Sensor	Specifications	Details
CH4 Methane	Technology:	MEMS transducer
	Detection Range:	50 - 1,000,000 PPM 2 SCFH @ 30' (10m) distance
	Resolution:	1 PPM
	Calibration:	Factory Calibrated
	Accuracy:	+/-10% > 300PPM (typical @ 20DegC / 50% RH)
	Temperature:	-40°C to +75°C
	Atmospheric:	80kPa – 120kPa
	Measurements Provided:	PPM, Temperature, Atmospheric Pressure, Absolute Humidity, Relative Humidity
	Damp Heat-Steady State:	500 hours @ 40°C/93% RH
	Temperature Cycling:	From -40°C to 85°C for 200 cycles
	Sand/Dust:	Sand: 150-850 µm SiO2 particle size, 23 m/s nom. velocity, 1.5 hrs @ 70°C per axis, 3 axes  Dust: Red China Clay, 1.5 m/s nom. velocity, 6 hrs @ 20°C and 6 hrs @ 70°C
Key Features:	Built-in environmental compensation · Inherently poison resistant · No calibration required · Supports 15+ year lifetimes	
H2S Hydrogen Sulfide	Future	Future
Refrigerants	Future	Future
Hydrogen	Future	Future
Flammables	Future	Future

## Measurement Modes

Sensor	Measurement Mode	Sensor Power & Measurement Frequency	Values Reported
CH4	Continuous	Sensor continuously powered. Values reported every 5 min or by exception.	PPM Atmospheric Pressure Ambient Temperature Relative Humidity Absolute Humidity
	Emissions	Sensor powered for 5 min at a set report interval. Values reported at the end of the 5 min sensor measurement time.	

## Specifications

Physical Specifications	
Dimensions	7.5" x3" (19cm x 7.62cm) - Without L shaped bracket
Weight	2 Lbs (0.9Kg)
Housing Material	Industrial polycarbonate UV rated
Enclosure Protection	IP67
Mechanical installation	L-Shape bracket with u-bolt
Electrical Specifications	
Input Power	72Ah four (4) D cell lithium battery pack. Field replaceable.
Battery Life	15 months in Continuous Sampling Mode. 44 months in Emissions Mode (Sampling @ 15 min). 48 months in Emissions Mode (Sampling @ 30 min)
Local Configuration	4-Pin serial configuration port. Requires SignalFire USB-4pin cable
Environmental	
Ambient Operating Temperature	-40 to +167°F (-40°C to 75°C)
Humidity	0% - 99% non-condensing
Communications	
Data Transmission	Report interval 5 seconds to 2 hours. Configurable measurement threshold to report on exception. Configurable sampling as fast as every 5 seconds.
Data Interface	Requires SignalFire's Gateway. Output of Gateway supports Modbus RTU, TCP, Ethernet/ IP, MQTT/ Sparkplug
RF Radio Power	40mW
RF Distance	0.5 mile (800 meters)
RF Band	902–928 MHz, FHSS, license-free ISM Band
Antenna	Internal Omni-directional Antenna
Gas Sensor	
CH4 (Methane)	See table for gas sensor specifications
Approvals	
Hazardous locations	Class 1 Division 1 Certified, Groups C, D. Temperature Code T4 Certified to CSA C22.2 No. 213:2017, Conforms to UL 121201:2017
ISM Band	Compliant with FCC Part 15, IC (Industry Canada)
Accessories	
USB-4 Pin Cable	USB cable with 4 pin adaptor. 3 feet long (1 meter)
4DPAK battery	72Ah battery pack with integrated fuse and super capacitor
Anti-Theft Locking Ring	Aluminum ring with security screws and bottom plate to lock cover on device
L-Shape bracket with U-Bolt (included when purchasing AirQScout)	Aluminum L-Shape bracket with U-bolt and mounting holes to install AirQScout

## Table of Contents

Gas Sensor Specification .....	2
Measurement Modes.....	2
Specifications.....	3
Table of Contents.....	4
Product Description .....	6
Connections and Components .....	7
Dimensions.....	8
How To Order.....	8
Setup.....	9
Using the SignalFire Toolkit.....	9
Network Setting .....	11
Modbus ID.....	11
Offline Mode.....	14
Sensor Error Codes .....	14
Remote Modbus Register Mapping.....	15
Modbus Registers.....	15
Register Map .....	15
Mounting and Care .....	16
Internal Lithium Battery Replacement.....	17
Cleaning Instructions.....	17
Configuration / Debug .....	17
Disposal .....	18
Lithium Primary Battery:.....	18
Electronic Components: .....	18
Metal Parts: .....	18
Packaging Materials: .....	18
Technical Support And Contact Information.....	21



WARNING: Use of this equipment in a manner not specified by the manufacturer may impair the protection provided by the equipment.

*AVERTISSEMENT: L'utilisation de cet équipement d'une manière non spécifiée par le fabricant peut nuire à la protection fournie par l'équipement.*



WARNING: The use of any parts not supplied by the manufacturer violates the safety rating of the equipment.

*AVERTISSEMENT: L'utilisation de pièces non fournies par le fabricant est contraire à la cote de sécurité de l'équipement.*

## Product Description

The AIRQ Scout is a modular wireless gas detection platform with integrated RF 900MHz wireless communications.

It monitors the presence of a gas and transmits the measurement wirelessly to a SignalFire Gateway or a RANGER900. The measurements are integrated in a supervisory system using Modbus communication at the gateway. When using the RANGER900, the measurements are transmitted to the SignalFire Cloud using LTE-M CAT M1 / NB-IoT cellular connectivity.

The smart gas sensor is powered from the built-in 72Ah battery. It uses the latest in smart gas sensor technology providing for low power demand, stable and accurate measurement as well as long term stability with little to no calibration required. It automatically compensates for temperature and humidity when sampling a measurement and therefore delivers accurate measurements with low drift. Its low power requirements allow for long battery life.

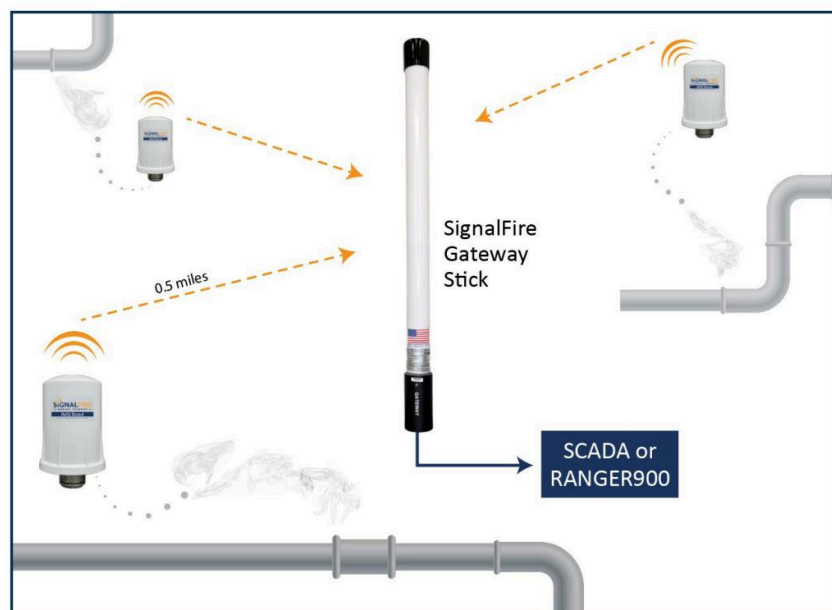

## FEATURES

- Integrated Methane gas sensor
- Integrated and protected antenna
- Continuous measurement or Scheduled
- Fast sensor sampling
- Reports sensor specific measurements
- Measurements include: PPM, LEL, Ambient, Temperature, Relative Humidity, Absolute Humidity
- 40mW radio, 0.5 mile range (800 meters)

## Connections and Components

### Radio LEDs

- The Radio TX LED (green) flashes each time a radio packet is sent. This LED will blink rapidly while searching for the radio network and at boot up.
- The Radio RX LED (red) blinks on each received radio packet.

### Status LEDs

- The STATUS LED (green) will blink on when the AirQ sensor is sampled.
- The ERROR LED (red) will blink to indicate an error condition.

### Scan/Checkin Button

- If this button is pressed the AirQ Scout will take a reading from the MEMS sensor and send the data to the gateway.

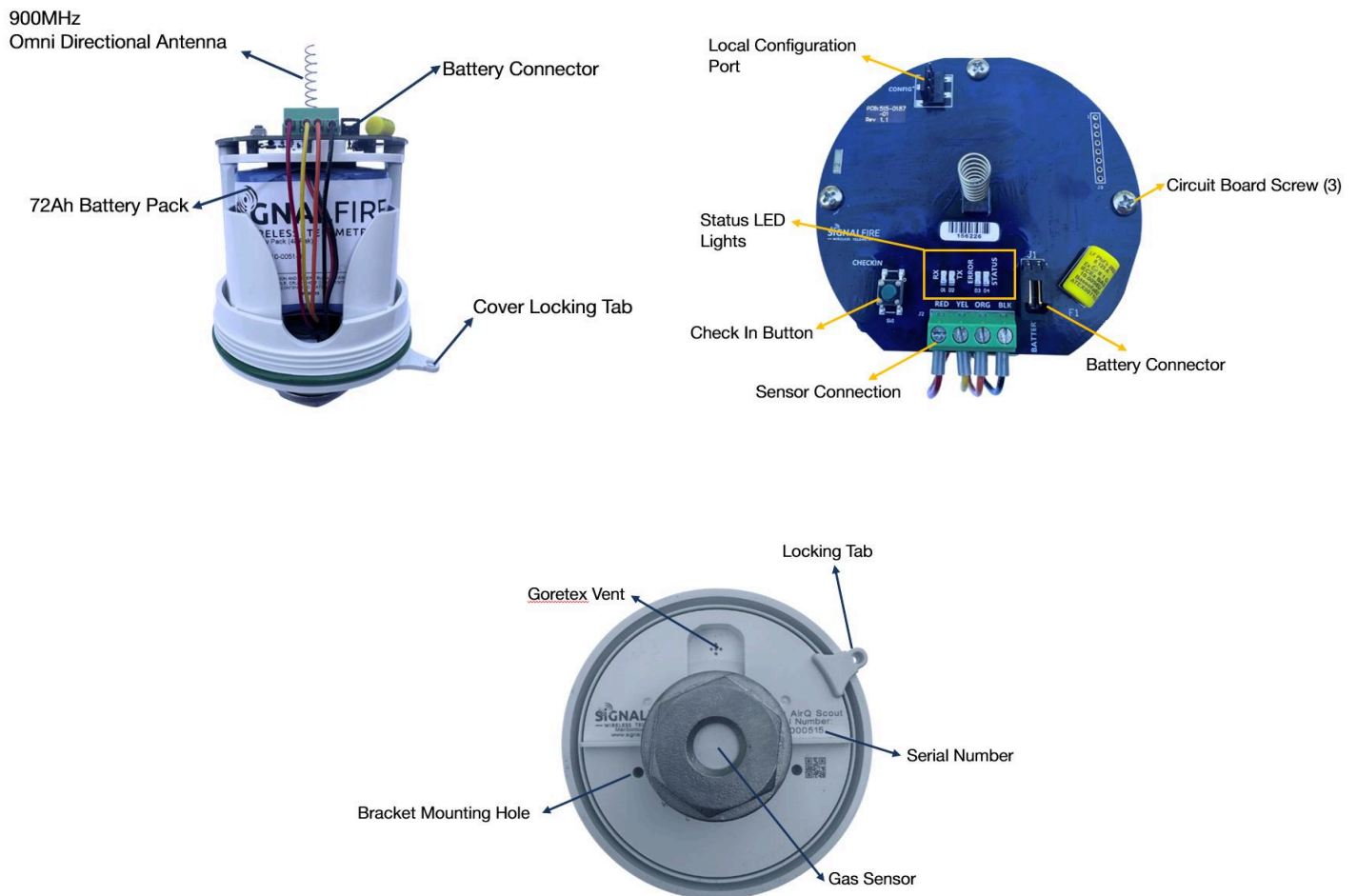

## Dimensions

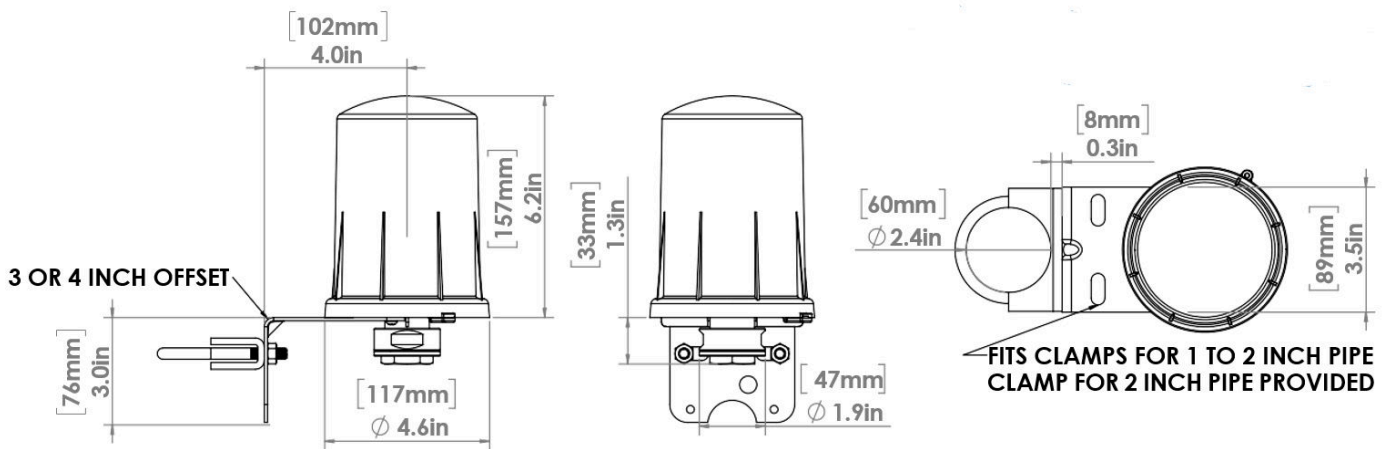

## How To Order

### AIRQ SCOUT WITH SIGNALFIRE 900MHZ RADIO

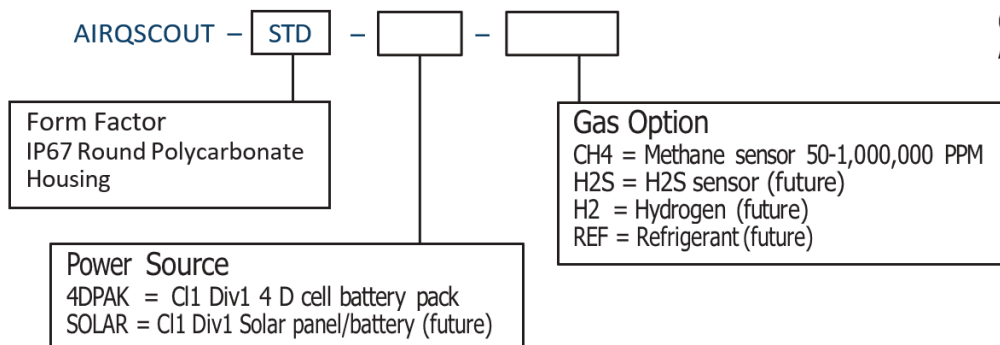

Order Code Example:  
AIRQSCOUT-STD-4DPAK-CH4

## Setup

The AirQ Scout needs to be set up for correct operation before being fielded. The configurable items include:

- Network selection
- Check-in period selection
- Modbus Server ID setting
- Optional alarm thresholds

All settings are made using the SignalFire Toolkit PC application and a USB-serial programming cable available from SignalFire.



**WARNING:** Perform the steps in this section (Setup) in a safe location only.

**AVERTISSEMENT:** Suivez les étapes de cette section (Configuration) dans un endroit sûr uniquement.

## Using the SignalFire Toolkit

The SignalFire Toolkit application can be downloaded at <https://www.signal-fire.com/signalfire-toolkit-software/>. After installation, launch the software and the main toolkit window will open:

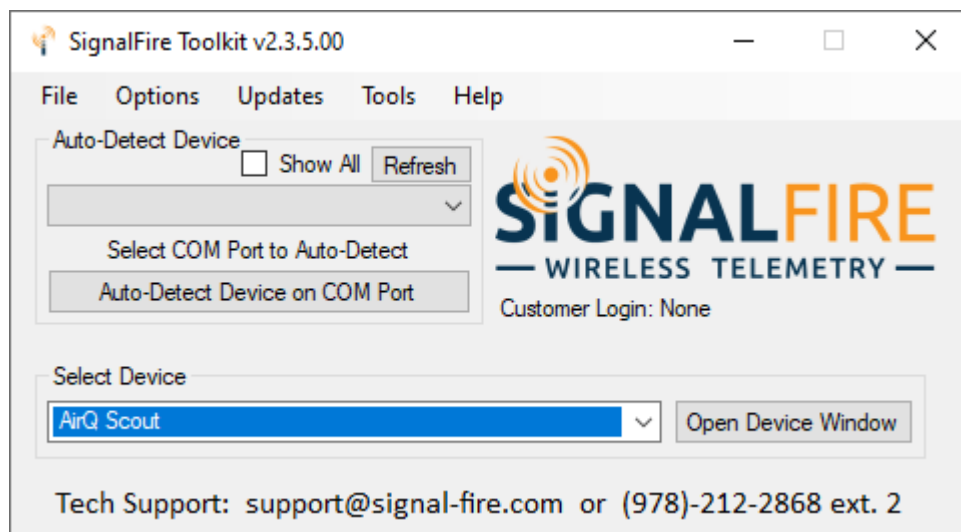

Select the COM port associated with the AirQ Scout and click “Auto-Detect Device on COM Port.” This will open the device configuration window, where all device settings can be configured.

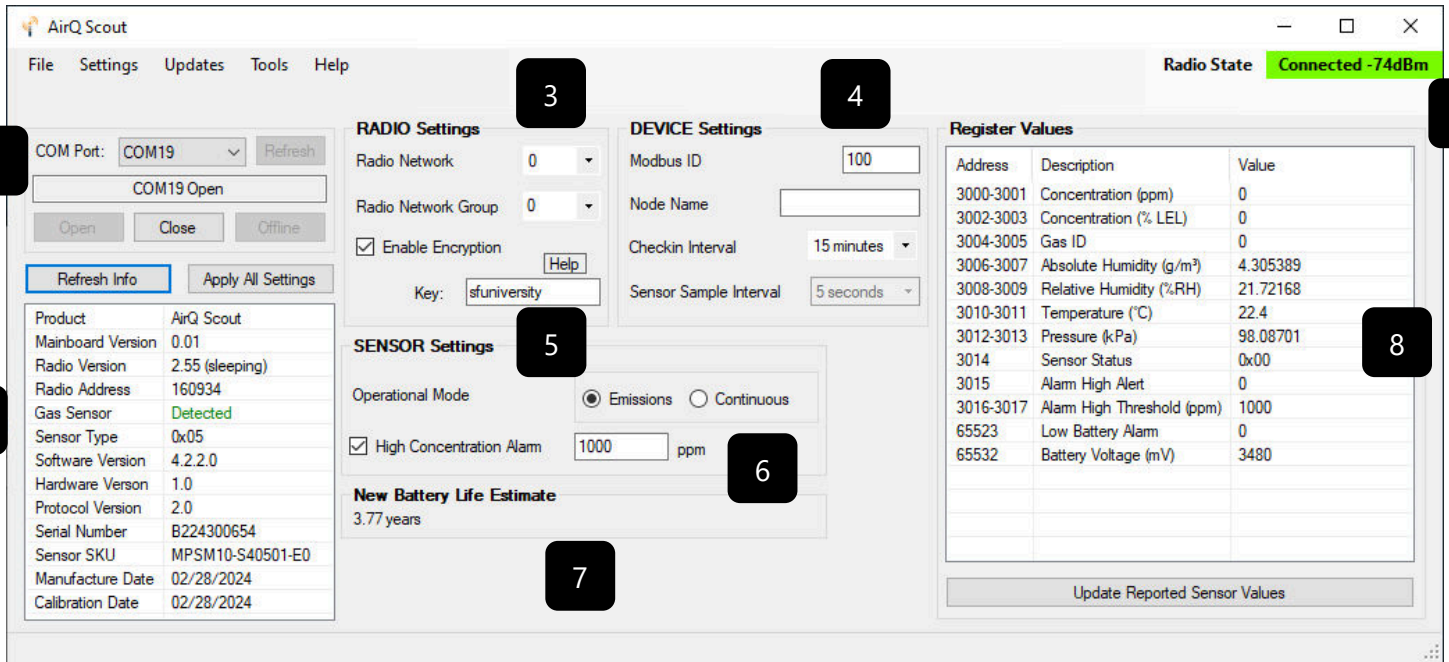

1	Serial Port Settings	2	Scout Information
3	Radio Settings	4	Node Device Settings
5	Operation Mode	6	Alarm Threshold Settings
7	Battery Life Estimate	8	Modbus Register Values
9	Connection Status		

## Network Setting

The network is set using the SignalFire Toolkit. The network, network group, and corporate ID/encryption key settings must match those of the gateway for them to communicate. When any setting is changed, it will be highlighted yellow, indicating it has not actually been written to memory. To apply the desired settings, click the **Apply All Settings** button in the upper left-hand corner, as indicated by the red box in the figure above.

## Encryption

To protect your over-the-air data and prevent tampering, SignalFire networks come with encryption.

To set up a AirQ Scout to use encryption, click the checkbox labeled **Enable Encryption** inside the **Set Corporate ID** box. All new AirQ come with this option enabled with "signalfire" as the default encryption key. The box will then change into a **Set Encryption Key** box, and it will prompt instead for the encryption key you



would like to use. Note that keys may not contain spaces or angle brackets. If you are setting up a new network, you will need to set the encryption key on all your devices. If you are adding an AirQ Scout to a legacy network, you can simply set the Corporate ID without clicking the Enable Encryption box, and it will remain compatible with the older system.

It is also possible to hide your encryption key so it cannot be read. This is the most secure option, but if you forget your key, there is no way to recover it – you must reset the key on every device on the network. To enable this option, select **Set Encryption Key Unrecoverable** under the **Settings** menu.

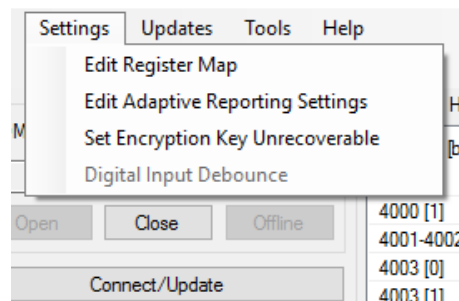

*Setting the encryption key to be unrecoverable.*

## Modbus ID

The Modbus ID can be set with the SignalFire Toolkit. Each remote device connected to the gateway must have a unique Modbus ID (1-240). Every SignalFire device must have a unique ID to prevent conflicts.

## Operation Mode

### Continuous

Sensor continuously powered and sampled every 5-seconds. Values reported every 15 min or immediately by exception. This mode should be used where rapid detection of gas detection is necessary

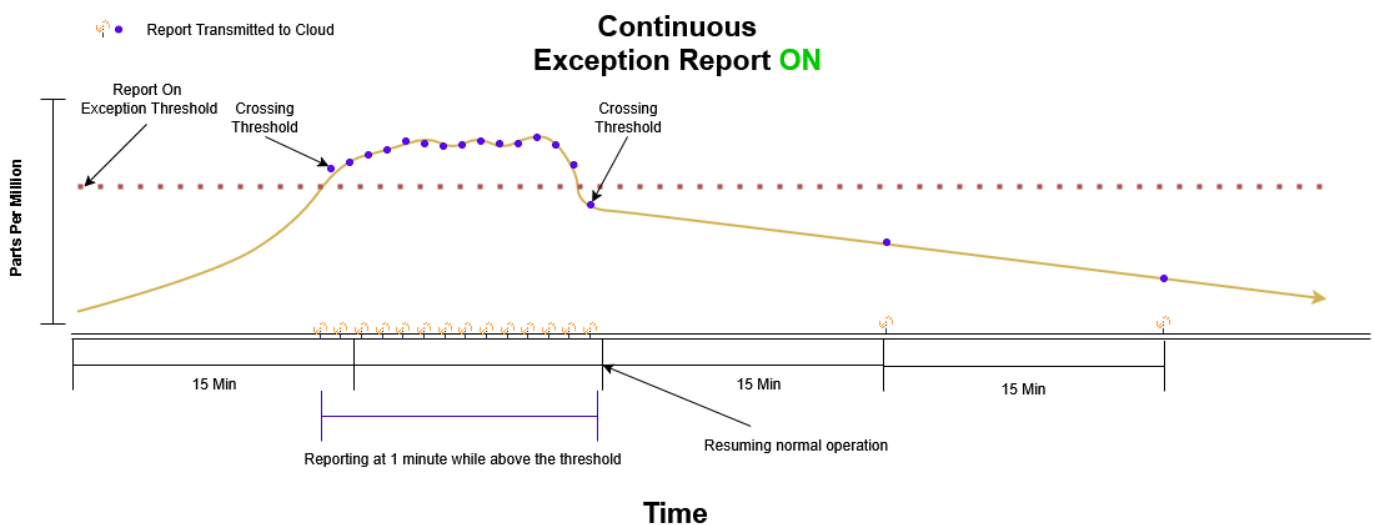
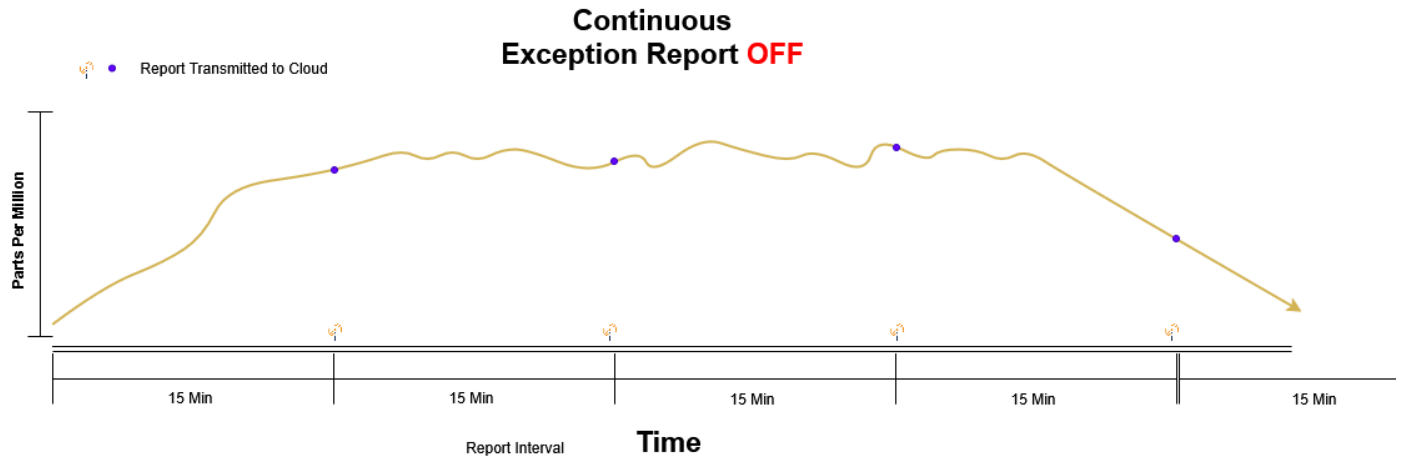

### Emissions

The default operating mode is emissions mode. In Emissions mode the RANGER will power the gas sensor every 10 minutes for 5-minutes and take 5-second samples during that period. The sensor values will be reported at the end of the 5-minute sample period, then the sensor will be powered off until the next report interval. When **High Concentration Alarm** is enabled, if during the 5-minute sample period the gas concentration crosses the configured threshold, the concentration will be reported immediately and then once a minute for as long as the concentration remains above the threshold. The report interval is configurable. This mode is useful for periodic sniffing for leaks and emissions.

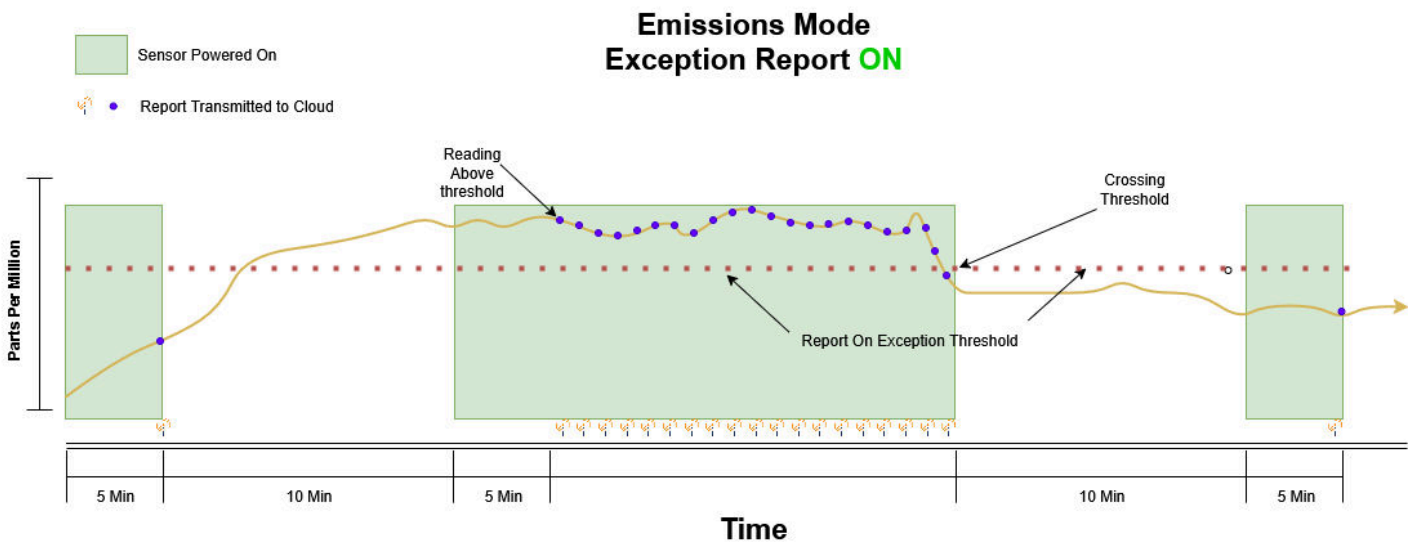
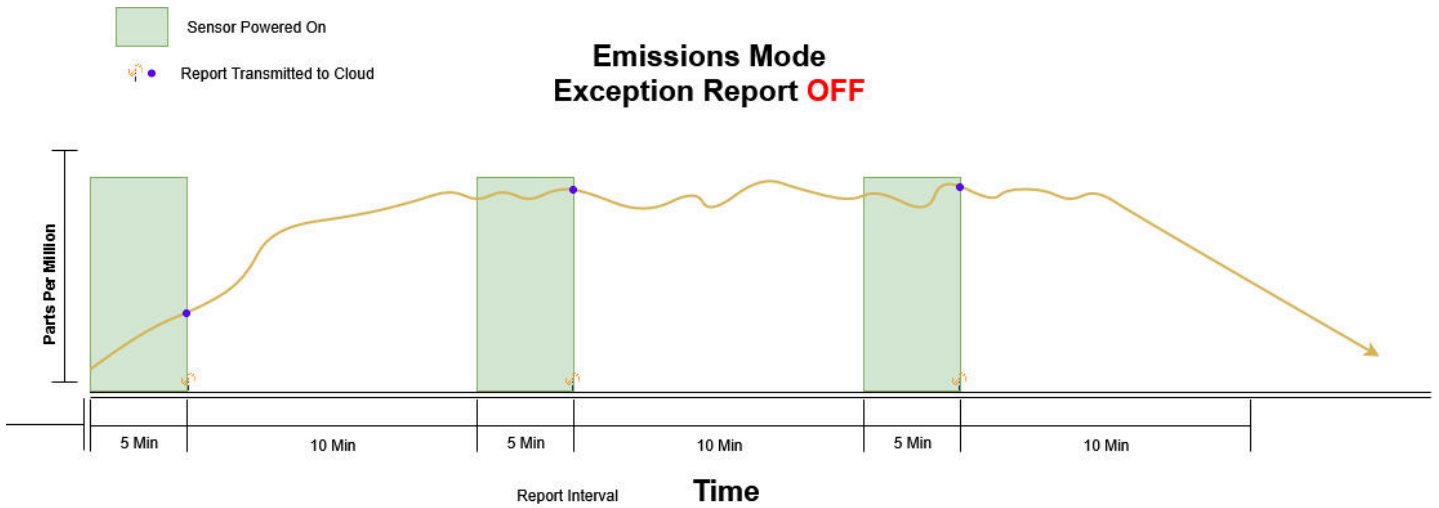

## AirQ Sensor Calibration

The AirQ sensor comes calibrated and does not require calibration in the field.

## Alarm Threshold Settings

Optional alarm threshold settings are available which allow for rapid AirQ sample interval (1 minute) and will cause the AirQ Scout to check-in immediately if the threshold is crossed. It will continue to report every 1 minute until the concentration goes **below** the High Concentration Alarm threshold.

High Concentration Alarm  ppm

*Setting the alarm thresholds.*

## Offline Mode

Offline Mode is implemented as a battery saving feature for cases when the AirQ Scout is unable to communicate with a Gateway. If the configured check-in interval is less than 15-minutes, and the AirQ Scout cannot contact a Gateway for two consecutive hours it will enter "offline mode". In offline mode the Scout will back off and only attempt to scan for the gateway every 15-minutes. This means that once a Scout enters offline mode, it will take it up to 15-minutes for the Scout to reconnect to a Gateway when the communication issue is resolved. Examples that would cause a Scout to enter offline mode include if it is powered up and installed prior to the Gateway being installed, or if the Gateway were to go offline due to loss of power or other failure.

## Sensor Error Codes

The AirQ Scout has the following error codes reported to register 3014 Sensor Status.

<b>Fault</b>	<b>Explanation</b>
<b>0x00</b>	No Errors
<b>0x01</b>	Failed Checksum
<b>0x02</b>	Illegal or Bad Parameter
<b>0x03</b>	Execution Failed
<b>0x04</b>	Insufficient Memory
<b>0x05</b>	Unknown Command
<b>0x07</b>	Incomplete Command
<b>0x21</b>	Internal Voltage Out of Range
<b>0x22</b>	Voltage Out of Range
<b>0x24</b>	Env Sensor Malfunction
<b>0x25</b>	Microcontroller Error
<b>0x26</b>	Sensor in Initialization Mode
<b>0x32</b>	Gas Sensing Element Malfunction

Table 1

## Remote Modbus Register Mapping

The Scout Node sends data to a SignalFire Telemetry Modbus Gateway. The data that is sent to the gateway is available at the gateway in registers where it can then be read by a Modbus RTU. Consequently, the node needs to have a unique (to the network it is in) Modbus ID which the gateway will use to store its unique data.

### Modbus Registers

Every check-in period, the sensors are read and data is sent to the gateway. The gateway will save the data under the set Modbus ID in 16-bit registers. The register map for this system is below.

### Register Map

Register Number	Register Address (Offset)	Description	Datatype
<b>43001-43002</b>	3000-3001	Concentration (ppm)	FLOAT
<b>43003-43004</b>	3002-3003	Concentration (%LEL)	FLOAT
<b>43005-43006</b>	3004-3005	Gas ID	FLOAT
<b>43007-43008</b>	3006-3007	Absolute Humidity (g/ml)	FLOAT
<b>43009-43010</b>	3008-3009	Relative Humidity (%RH)	FLOAT
<b>43011-43012</b>	3010-3011	Temperature	FLOAT
<b>43013-43014</b>	3012-3013	Pressure (kPa)	FLOAT
<b>43015</b>	3014	Sensor Status (see Table 1)	UINT16
<b>43016</b>	3015	Alarm High Aert	UINT16
<b>43017-43018</b>	3016-3017	Alarm High Threshold (ppm)	FLOAT
<b>65523</b>	65523	Low Battery Aam	UINT16
<b>65532</b>	65532	Batt Volt	UINT16

## Mounting and Care

The AirQ Scout comes with a mounting bracket and U-Bolt for mounting to a vertical 2" pipe

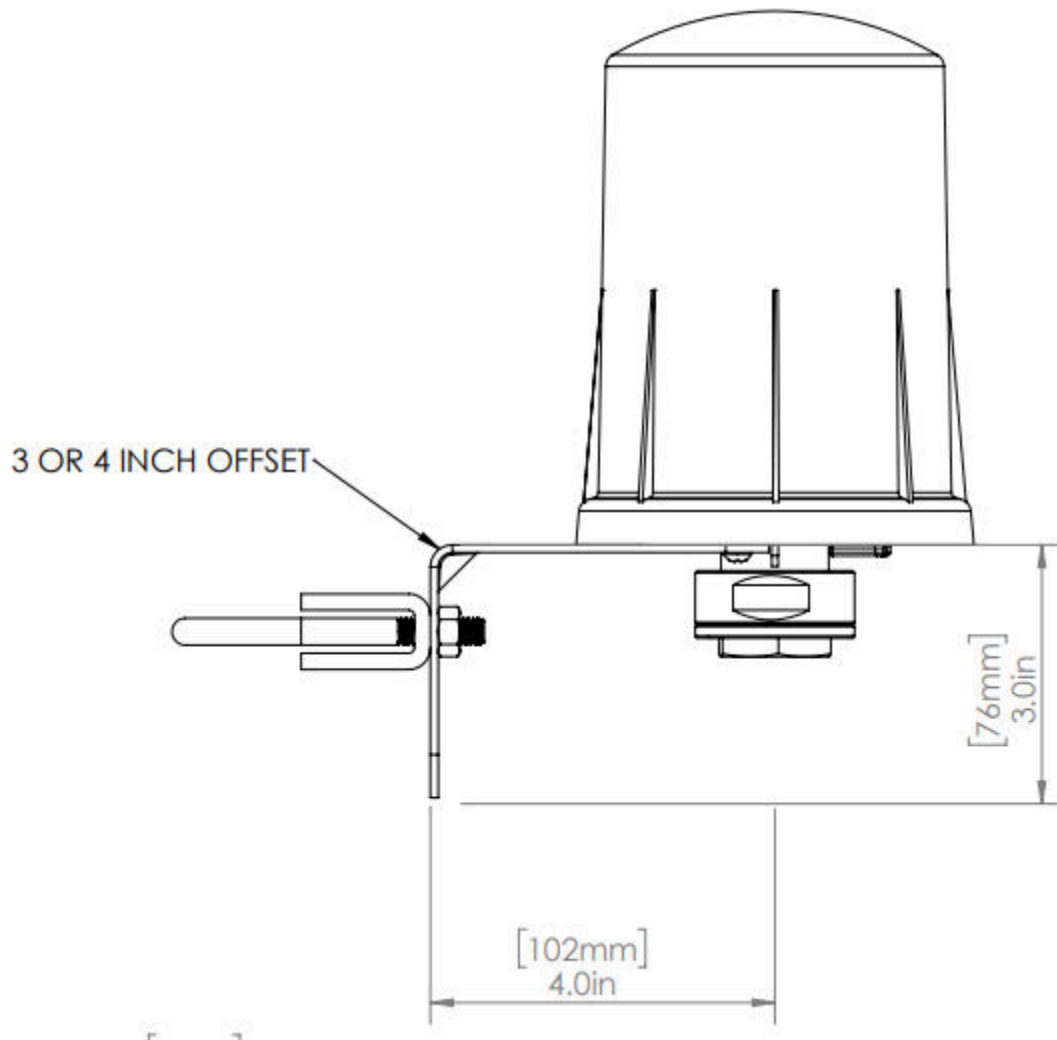

**WARNING:** The AIRQ SCOUT must be mounted in a location free of high vibrations. Over time vibrations can damage the AirQ or battery pack, which could impair its safety ratings. Do not mount directly to continuous vibrating equipment such as pumps or compressors.

## Internal Lithium Battery Replacement

Battery Packs can be changed with the node in place.

1. Unscrew the cover from the base.
2. Unplug the battery from the PCB, by depressing the locking clip on the connector.
3. Loosen the three screws that attach the circuit board assembly to the base.
4. Remove/Replace the battery.
5. Re-Install circuit board assembly. Do not overtighten the screws.
6. Connect the battery to the main PCB battery connector
7. Install the enclosure cover.



**WARNING:** Use of any battery other than the SignalFire part number 4DPak will impair the protection provided by the equipment.

**AVERTISSEMENT:** L'utilisation d'une pile autre que la référence SignalFire 4DPak compromettra la protection fournie par l'équipement.

## Cleaning Instructions

The outside of the enclosure may be cleaned with water, mild soap, and a damp cloth as needed. High Pressure washing is not recommended.



**WARNING:** Electrostatic Discharge Hazard! Care must be taken to avoid the potential of creating a change on the enclosure or antenna. Do not wipe with a dry cloth. Do not brush against the enclosure with clothing or gloves.

**AVERTISSEMENT:** Risque de décharge électrostatique! Il faut veiller à éviter tout risque de changement de l'enceinte ou de l'antenne. Ne pas essuyer avec un chiffon sec. Ne pas brosser contre l'enceinte avec des vêtements ou des gants.

## Configuration / Debug



**WARNING:** Only connect to the debug port in a safe area!

**AVERTISSEMENT:** Se connecter uniquement au port de débogage dans une zone sûre!

Debug and configuration information is available if a connection is made via the debug port on the main board. A USB converter cable (USB-Serial-4PIN, available from SignalFire) must be used for this interface.

Debug and advanced configuration may be done using the SignalFire Toolkit PC application.

## Disposal

To ensure environmental safety and compliance, please follow these disposal instructions for the product and its components:

### Lithium Primary Battery:

This product contains lithium primary batteries, which must be removed before disposal. Lithium batteries must be recycled through specialized facilities due to their fire risk. Do not place batteries in regular trash.

### Electronic Components:

This product contains electronics must be recycled through approved e-waste recycling programs. Electronics can contain harmful materials and should be prevented from entering landfills. Do not place electronics in regular trash.

### Metal Parts:

Any metal components can be separated and recycled through your local metal recycling facility.

### Packaging Materials:

Recycle or reuse packaging materials such as cardboard or plastics, following local recycling guidelines.

For local disposal sites refer to:

- [Call2Recycle](#) (USA, Canada)
- [Earth911](#) (USA, Canada)
- [SERI](#) (International)

In the USA or more information, visit:

- [EPA's battery disposal guide](#)
- [EPA's electronics recycling page](#)

By following these guidelines, you help reduce waste and support environmental sustainability.

<b>Revision</b>	<b>Date</b>	<b>Changes/Updates</b>
<b>1.0</b>	5/1/25	Initial release
<b>1.2</b>	2/4/26	Added tables for gas sensor specifications and measurement modes. Added C1D1 Certified.
<b>1.3</b>	3/18/26	Updated FCC and ISED standards
<b>1.4</b>	6/19/26	Updated formatting

## **APPENDIX - FCC and IC Statements**

Changes or modifications not expressly approved by SignalFire Telemetry, Inc could void the user's authority to operate the equipment.

This device complies with Part 15 of the FCC Rules. Operation is subject to the following two conditions: (1) this device may not cause harmful interference, and (2) this device must accept any interference received, including interference that may cause undesired operation.

This equipment has been tested and found to comply with the limits for a Class B digital device, pursuant to Part 15 of the FCC Rules. These limits are designed to provide reasonable protection against harmful interference in a residential installation. This equipment generates, uses and can radiate radio frequency energy and, if not installed and used in accordance with the instructions, may cause harmful interference to radio communications. However, there is no guarantee that interference will not occur in a particular installation. If this equipment does cause harmful interference to radio or television reception, which can be determined by turning the equipment off and on, the user is encouraged to try to correct the interference by one of the following measures:

- Reorient or relocate the receiving antenna.
- Increase the separation between the equipment and receiver.
- Connect the equipment into an outlet on a circuit different from that to which the receiver is connected.
- Consult the dealer or an experienced radio/TV technician for help.

### **WARNING!**

#### **FCC and IC Radiation Exposure Statement:**

This equipment complies with FCC's and IC's RF radiation exposure limits set forth for an uncontrolled environment under the following conditions:

1. This equipment should be installed and operated such that a minimum separation distance of 20cm is maintained between the radiator (antenna) & user's/nearby person's body at all times.
2. This transmitter must not be co-located or operating in conjunction with any other antenna or transmitter.

Under Industry Canada regulations, this radio transmitter may only operate using an antenna of a maximum (or lesser) gain approved for this transmitter by Industry Canada. To reduce potential radio interference to other users, the antenna type and its gain should be so chosen that the equivalent isotropically radiated power (e.r.i.p.) is not more than that necessary for successful communication.

*Conformément à la réglementation d'Industrie Canada, le présent émetteur radio peut fonctionner avec une antenne d'un type et d'un gain maximal (ou inférieur) approuvé pour l'émetteur par Industrie Canada. Dans le but de réduire les risques de brouillage radioélectrique à l'intention des autres utilisateurs, il faut choisir le type d'antenne et son gain de sorte que la puissance isotrope rayonnée équivalente (p.i.r.e.) ne dépasse pas l'intensité nécessaire à l'établissement d'une communication satisfaisante.*

This device complies with Industry Canada license-exempt RSS standard(s). Operation is subject to the following two conditions. (1) This device may not cause harmful interference, and (2) this device must accept any interference received, including interference that may cause undesired operation.

L'émetteur/récepteur exempt de licence contenu dans le présent appareil est conforme aux CNR d'Innovation, Sciences et Développement économique Canada applicables aux appareils radio exempts de licence. L'exploitation est autorisée aux deux conditions suivantes :

- 1) L'appareil ne doit pas produire de brouillage;
- 2) L'appareil doit accepter tout brouillage radioélectrique subi, même si le brouillage est susceptible d'en compromettre le fonctionnement.

# Technical Support And Contact Information

SignalFire Telemetry  
140 Locke Dr., Suite B  
Marlborough, MA 01749

(978) 212-2868  
[support@signal-fire.com](mailto:support@signal-fire.com)

