

8 7 6 5 4 3 2 1

F
E
D
C
B
A

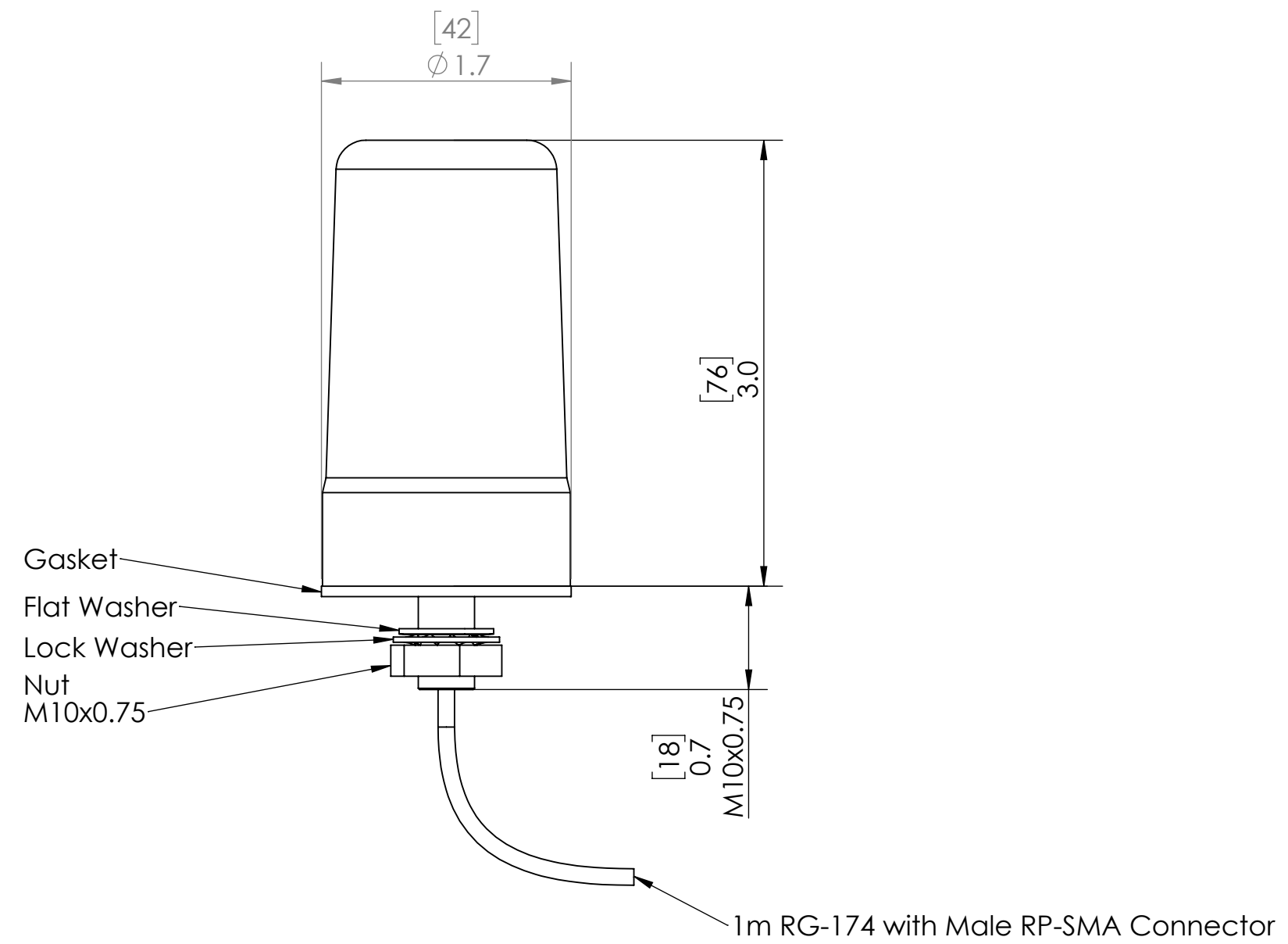

Order Code: Ext-Ant

	Specification
Frequency	902~928MHz
Gain	5.8dBi
V.S.W.R.	< 2.7
Impedance	50 Ohm
Cable, Connector	RG-174, 1m,RP-SMA, Male
Polarization	Linear, Vertical
Dimension	42(Dia.) x 75.6 (H)
Ingress Rating	IPX7
Operation Temperature	-40 to +80°C
Storage Temperature	-40 to +85°C

PROPRIETARY AND CONFIDENTIAL
THE INFORMATION CONTAINED IN THIS DRAWING IS THE SOLE PROPERTY OF SIGNALFIRE TELEMETRY. ANY REPRODUCTION IN PART OR AS A WHOLE WITHOUT THE WRITTEN PERMISSION OF SIGNALFIRE TELEMETRY IS PROHIBITED.

UNLESS OTHERWISE SPECIFIED:	NAME	DATE
DIMENSIONS ARE IN INCHES	DRAWN	S.BLODGETT 5/1/2019
TOLERANCES:	CHECKED	
FRACTIONAL $\pm 1/64$	ENG APPR.	
ANGULAR: MACH. $\pm 1/2^\circ$	MFG APPR.	
TWO PLACE DECIMAL $\pm .01$	Q.A.	
THREE PLACE DECIMAL $\pm .005$	COMMENTS:	
INTERPRET GEOMETRIC TOLERANCING PER:		
MATERIAL		
FINISH		
DO NOT SCALE DRAWING		

SignalFire Telemetry	
TITLE: Mechanical Drawing, Ext-Ant	
DWG. NO. 965-0058-01	REV A
SCALE 1:1	SHEET 1 OF 1

8 7 6 5 4 3 2 1