

Interface Manual

Multi I/O System

SignalFire Number: MIOM

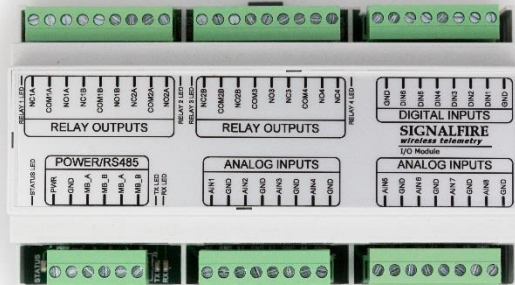

The SignalFire Multi I/O System is used with a SignalFire Modbus Stick running “MIOM” firmware. It allows the user to interface to a variety of sensors or control devices from a single wireless node. It is DIN rail mounted and designed to be easy to use.

The SignalFire Multi I/O System has the following features:

- Controlled by a SignalFire Multi I/O Stick
- 8 analog inputs (0-20mA or 0-5V)
- 6 digital inputs (state and counter up to 1kHz)
- 4 relay outputs (2 DPDT, 2 SPST)
- Relay failsafe timers with optional latching
- Wide range DC power input. 6 to 36VDC
- Very low power consumption
- DIN Rail mount with pluggable screw terminal blocks
- Status LEDs
- Connect up to 8 modules to one Multi I/O stick
- Analog scaling configuration
- Alarm threshold reporting
- Local alarm relay override control

Specifications

2

Power	6 – 36VDC (5mA max @12V no relays energized, 40mA max @12V with all relays energized)
Operating Temp	-40°C to +80°C
Analog Inputs	0-10V Max, 0-20mA
Digital Inputs	Dry Contact or 30 Volts Max

Connections and Components

The Multi I/O module provides screw terminals for connection to a SignalFire Multi I/O stick RS485 **A** and **B** terminals. A second set of A/B RS485 terminals are available for daisy chaining multiple modules.

Power must be provided by the **Power Input** screw terminals (10-30VDC). The Module power requirements at 12VDC is only 2mA plus 7.5mA per energized relay channel.

Status LEDs

The Multi I/O module has a green status LED which blinks indicating the module is running. In addition there are TX/RX LEDs to indicate RS485 messages to/from the Multi I/O stick.

Each relay output also has a green LED which turns on while the relay is energized.

Operation

Relay Outputs

The four digital outputs will be relays with two of them being SPDT and two being DPDT.

There are two ways to control the relays:

- **Direct Control:** The PLC writes to a coil register to energize or de-energize the relay.
- **Pulse Control:** The PLC writes to a holding register with a number of seconds to energize the relay. For example, if you write a 5 to this register, the relay will be energized for 5 seconds and then automatically de-energize.

Analog Scaling

The analog inputs can be scaled so that they will report a 32 bit floating point number. For example, a 4-20mA analog input could be scaled to 0.0 to 5000.0 PSI and you could read the actual PSI reading at the Gateway.

Digital Input Alarm

One digital input can be designated to act as an alarm channel. Whenever the state of this input changes, an immediate update of all registers will be forwarded to the gateway.

Analog Input Alarms

Up to four of the analog inputs can be configured with an alarm threshold. Whenever any of the configured inputs exceeds the threshold an immediate update of all registers will be forwarded to the gateway. In addition, as long as any alarm threshold is exceeded, all registers will be forwarded to the gateway every 15 seconds.

Relay Alarm Override

Each relay can optionally be configured so that if the selected alarm threshold is crossed the relay is automatically de-energized.

Configuration

Slave ID

The Multi I/O module only requires that the module ID be configured with the DIP switch. Valid module IDs are 1 through 8. These are entered on the DIP switch in binary fashion. The Multi-I/O stick will automatically detect which modules are connected.

Analog Inputs

The analog inputs may operate in either current (0-20mA/4-20mA), or voltage (0-5V/1-5V). The input mode must be set by slide switches inside the module. Slide the switch corresponding to the input channel up to **Volts** for a voltage input, or down to **mA** for a current input. To do this, first remove the cover using a small flathead screwdriver. The cover is held on by clips.

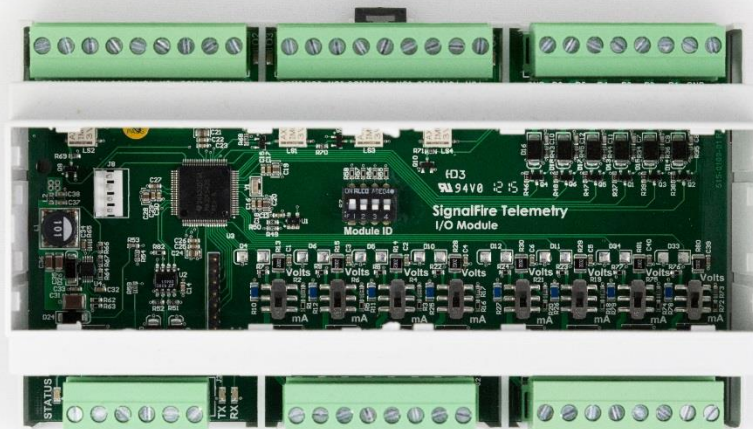

Analog/Relay Module with cover removed

Wire the analog voltage or current to the 8 individual sets of screw terminals. Maximum input voltage (for either current or voltage input mode) is 10 Volts. The compliance voltage for a 4-20mA device must be provided externally. See wiring diagram for details.

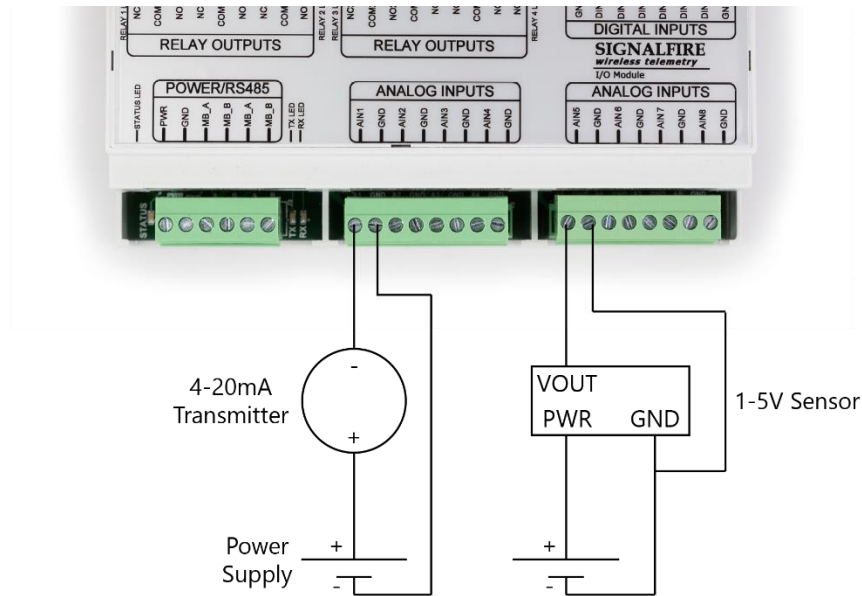

An example of a 4-20mA transmitter connected to AIN1 and a 1-5V sensor connected to AIN5 is shown above. Note that generally the same power supply being used to power the MIOM system would be used to provide power for the attached sensors.

Digital Inputs

The digital inputs (6 total) can be dry contact or voltage (30 Volts max). Be sure to connect the ground bus from the module to either the ground of the voltage device or the dry contact.

Digital (Relay) Outputs

There are four relay outputs. Two of the relays are SPDT and two are DPDT relays. The relays are rated for the following:

- 30 VDC @ 2 Amps
- 250 VAC @ 0.25 Amps

Hazardous Location Certification

7

The MIO Module is rated Class 1 Division 2 non-incendive.

SignalFire Telemetry Hudson, MA www.signal-fire.com	
Model: MIOM	S/N: 00000001
 Class I, Division 2 Groups C, D T4	Voltage: 6 – 36 VDC Current: 100 mA Max Temperature: –40°C to +85°C
Certified to CSA C22.2 No. 142 and CSA C22.2 No. 213 Conforms to ISA 12.12.01 and UL 916	
WARNING – EXPLOSION HAZARD Substitution of components may impair suitability for Class I, Division 2 AVERTISSEMENT - RISQUE D'EXPLOSION. La substitution de composants peut rendre ce matériel inacceptable pour les emplacements de classe I, division 2	WARNING – EXPLOSION HAZARD Do not connect while circuit is live unless area is known to be nonhazardous AVERTISSEMENT - RISQUE D'EXPLOSION. Ne pas débrancher tant que le circuit est sous tension, à moins qu'il ne s'agisse d'un emplacement non dangereux.



WARNING: Exposure to some chemicals may degrade the sealing properties of materials used in the output relays.



AVERTISSEMENT: L'exposition à certains produits chimiques peut dégrader les propriétés d'étanchéité de MATERIALS utilisés dans les dispositifs suivants:

- Relais de sortie

Use with SignalFire Multi I/O Telemetry "Stick" Radio

When connected to a SignalFire MIOM Stick (contact SignalFire for more detail), additional configuration may be done by connecting to the Multi I/O stick with the SignalFire Toolkit.

The following items are configured using the Toolkit

- Load Multi-IO Firmware
- Radio Network Selection
- Modbus Slave ID
- Relay Failsafe Timers (optional)
- Relay latching (optional)
- Node Name (optional)
- Analog Scaling (optional)
- Analog Alarms (optional)
- Digital Alarm (optional)
- Radio Range (select short range if stick is less than 30' away from the gateway)

Multi-IO Stick

File Settings Updates Tools Help

Passed

COM Port: COM3 Refresh

COM3 Open

Open Close Offline

Connect/Update

Product	MULTI-IO
Slave ID	64
Node Name	not set
Radio Connectivity	DISCONNECTED
Mainboard Version	0.09
Radio Version	2.49
Radio Address	9999
Corporate ID	0
Radio Network	3
Radio Network Group	0
Radio Power (dBm)	5
Radio Range	Long Range
Checkin Interval	1 minute

Reported Module Values

16-bit Module Header Registers			16-bit Data Registers			32-bit Data Registers		
Addr	Description	Value	Addr	Description	Value	Addr	Description	Value
1000	Module Type	2 (Multi-IO)	1400	Analog Input 1	0 uA	1418	Scaled AI1	0
1001	Number of Modules	1	1401	Analog Input 2	0 uA	1419	Scaled AI2	2.75
1002	Module Bitmask	8 (00001000)	1402	Analog Input 3	0 uA	1420	Scaled AI3	4.75
1003	Module 1 Alarm DI	0	1403	Analog Input 4	0 uA	1421	Scaled AI4	0
1004	Module 2 Alarm DI	0	1404	Analog Input 5	0 uA	1422	Scaled AI5	0
1005	Module 3 Alarm DI	0	1405	Analog Input 6	0 uA	1423	Scaled AI6	0
1006	Module 4 Alarm DI	0	1406	Analog Input 7	0 uA	1424	Scaled AI7	0
1007	Module 5 Alarm DI	0	1407	Analog Input 8	0 uA	1425	Scaled AI8	0
1008	Module 6 Alarm DI	0	1408	Digital Input 1 State	0	1426	DI1 Counter	4
1009	Module 7 Alarm DI	0	1409	Digital Input 2 State	0	1427	DI2 Counter	2
1010	Module 8 Alarm DI	0	1410	Digital Input 3 State	0	1428	DI3 Counter	10
1011	Relay Latch Bitmask	0 (00000000)	1411	Digital Input 4 State	0	1429	DI4 Counter	37
9995	Supply Voltage (mV)	9044	1412	Digital Input 5 State	0	1430	DI5 Counter	5

ENERGIZE DE-ENERGIZE -->

ENERGIZE DE-ENERGIZE -->

ENERGIZE DE-ENERGIZE -->

ENERGIZE DE-ENERGIZE -->

Update Reported Module Values

Refresh Settings

Settings

Radio Range Long Range Set

Radio Network 3 Set

Radio Network Group 0 Set

Checkin Interval 1 minute Set

Node Name Set

Slave ID 64 Set

Relay Communication Failsafe Timer (min) Disabled Set

Relay Message Failsafe Timer (min) Disabled Set

Module Failsafe Timer (min) Disabled Set

Analog Inputs

Input 1	Input 2	Input 3	Input 4	Input 5	Input 6	Input 7	Input 8
Scale Low (units)	3	5					
Scale High (units)	4	6					

Set Analog Scaling

Alarm Enable (4)

Set Analog Alarms

Alarm Threshold 5000 8000

Digital Inputs

Input 1	Input 2	Input 3	Input 4	Input 5	Input 6	None
Alarm Enable (1)	<input type="checkbox"/>	<input type="checkbox"/>	<input checked="" type="checkbox"/>	<input type="checkbox"/>	<input type="checkbox"/>	<input type="checkbox"/>

Set Digital Alarm

Relay Outputs

Relay 1	Relay 2	Relay 3	Relay 4
Failsafe Enable	<input type="checkbox"/>	<input type="checkbox"/>	<input type="checkbox"/>
Failsafe Latch	<input type="checkbox"/>	<input type="checkbox"/>	<input type="checkbox"/>
Alarm Override	None	AI1	None

Set Relay Options

Success

The settings and values for one module at a time are displayed. Selecting a module and clicking on **Update Reported Sensor Values** will cause the data to be refreshed and forwarded to the gateway for the selected module. Each relay channel has an **Energize** and **De-Energize** button which can be used to toggle the relay state for testing.

Analog Scaling

For each analog input, on each module, analog scaling can be enabled. This will scale the analog input to a floating point number available at the gateway. For example the window above shows analog input 1 scaled from 0 to 1000.

Digital Input Alarm

One digital input channel from each module can be defined as the digital alarm channel. This will cause the data to be sent to the gateway on any change of the selected input.

Digital Input Debounce

In cases where it is desired to accurately totalize digital input counts it may be necessary to enable the digital input debounce timer. The debounce timer is useful when dealing with dry contacts that may otherwise produce extra counts when they close. To enable the digital debounce select **Digital Input Debounce** from the **Settings** drop-down menu. A typical value for a dry contact would be 100mS. Any extra counts due to contact bounce within the debounce time setting will be ignored.

Analog Input Alarms

Up to 4 analog inputs from each module can be configured to have an alarm. Both the **Alarm Enable** check box must be selected and an **Alarm Threshold** must be entered.

Note: If analog scaling is enabled the alarm threshold must be entered in the scaled units. If analog scaling is not configured the alarm threshold is entered in μA or mV depending on the input type.

Relay Failsafe Timers

The Multi-IO module (MIOM) supports three configurable failsafe timers which are used to de-energized selected relays in the event of a communication failure.

- **Relay Communication Failsafe Timer:** This timer will count down in the event of a loss of radio communications with the SignalFire wireless network.
- **Relay Message Failsafe Timer:** This timer is reset anytime a coil write for any relay is received from the Gateway/PLC. This is used to protect against communications failures between the Gateway and the PLC.
- **Module Failsafe Timer:** This timer is kept by each individual module and is reset each time the module receives a message from the MIOM stick. This timer is to protect against a loss of communications between the MIOM stick and a module.

If any timer expires, all relays selected for Failsafe Enable will be de-energized.

When any relay is de-energized from a failsafe timer it will only be energized when a valid coil write is received from the PLC/Gateway.

Relay Failsafe Latch

For each relay that is enabled for a failsafe timer optionally a "Failsafe Latch" can be enabled. If the failsafe latch is enabled any time a relay is de-energized for any reason (including a coil write, failsafe timer, or power cycle), the relay will remain de-energized until coil write is written to the correct "un-latch" register. Coil writes to the standard relay control register will not be executed while the relay is in the latched state. A header register is provided to indicate that a module currently has a relay in the latched state.

Relay Alarm Override

Each relay can be set to have a local override which will automatically de-energize the relay channel if the configured alarm crosses the alarm threshold. As long as the alarm condition is met the relay will remain de-energized and cannot be switched on by Modbus writes. Once the alarm condition is cleared the relay will remain in the de-energized state until it is commanded energized by a Modbus write from the PLC.

Configuration Via Modbus

In addition to configuring the module settings using the SignalFire Toolkit, the settings can be viewed and changed remotely via Modbus.

Modbus Register Map

The status registers are reported even if no modules are detected. For each module detected the register map for that module is reported. Below are the module register maps for modules 1, 2, and 8. Modules 3-7 follow the same addressing convention.

Status Registers

Register Address	Register Number	Description	Function Codes
Holding Registers (4xxxx)			
<i>Read-only</i>			
1000	41001	Module Type (2 = Multi-IO Module(s))	03, 04
1001	41002	Number of Modules Detected	03, 04
1002	41003	Modules Detected (bitmask, LSB = Module 1)	03, 04
1003	41004	Module1 Alarm DI State	03, 04
1004	41005	Module2 Alarm DI State	03, 04
1005	41006	Module3 Alarm DI State	03, 04
1006	41007	Module4 Alarm DI State	03, 04
1007	41008	Module5 Alarm DI State	03, 04
1008	41009	Module6 Alarm DI State	03, 04
1009	41010	Module7 Alarm DI State	03, 04
1010	41011	Module8 Alarm DI State	03, 04
1011	41012	Relay(s) Latched (bitmask, LSB = Module 1)	03, 04
9987	49988	Major revision number for the mainboard	03, 04
9988	49989	Minor revision number for the mainboard	03, 04
9989	49990	Major revision number for the radio	03, 04
9990	49991	Minor revision number for the radio	03, 04

Register Address	Register Number	Description	Function Codes
Coils (0xxxx)			
<i>Write-only</i>			
101	00102	Relay1 Coil	05
102	00103	Relay2 Coil	05
103	00104	Relay3 Coil	05
104	00105	Relay4 Coil	05
111	00112	Counter1 Reset Coil	05
112	00113	Counter2 Reset Coil	05
113	00114	Counter3 Reset Coil	05
114	00115	Counter4 Reset Coil	05
115	00116	Counter5 Reset Coil	05
116	00117	Counter6 Reset Coil	05
131	00132	Relay1 Force Unlatch Coil	05
132	00133	Relay2 Force Unlatch Coil	05
133	00134	Relay3 Force Unlatch Coil	05
134	00135	Relay4 Force Unlatch Coil	05
Holding Registers (4xxxx)			
<i>Write-only</i>			
121	40122	Relay1 Pulse (0 = Off, 1 – 255 = Pulse Time (sec))	06
122	40123	Relay2 Pulse	06
123	40124	Relay3 Pulse	06
124	40125	Relay4 Pulse	06
<i>Read-only</i>			
1100	41101	AI1: Current or Voltage Reading (Unsigned int, μ A or mV)	03, 04
1101	41102	AI2: Current or Voltage Reading	03, 04
1102	41103	AI3: Current or Voltage Reading	03, 04
1103	41104	AI4: Current or Voltage Reading	03, 04
1104	41105	AI5: Current or Voltage Reading	03, 04
1105	41106	AI6: Current or Voltage Reading	03, 04
1106	41107	AI7: Current or Voltage Reading	03, 04
1107	41108	AI8: Current or Voltage Reading	03, 04
1108	41109	DI1: State (Unsigned int, 1 = Closed or 0 = Open)	03, 04
1109	41110	DI2: State	03, 04
1110	41111	DI3: State	03, 04
1111	41112	DI4: State	03, 04
1112	41113	DI5: State	03, 04
1113	41114	DI6: State	03, 04
1114	41115	Relay #1 State (Unsigned int, 1 = ON or 0 = OFF)	03, 04
1115	41116	Relay #2 State	03, 04

1116	41117	Relay #3 State	03, 04
1117	41118	Relay #4 State	03, 04
1118	41119	AI1: Scaled Reading (Float, High Word)	03, 04
1119	41120	AI1: Scaled Reading (Float, Low Word)	03, 04
1120	41121	AI2: Scaled Reading	03, 04
1121	41122	AI2: Scaled Reading	03, 04
1122	41123	AI3: Scaled Reading	03, 04
1123	41124	AI3: Scaled Reading	03, 04
1124	41125	AI4: Scaled Reading	03, 04
1125	41126	AI4: Scaled Reading	03, 04
1126	41127	AI5: Scaled Reading	03, 04
1127	41128	AI5: Scaled Reading	03, 04
1128	41129	AI6: Scaled Reading	03, 04
1129	41130	AI6: Scaled Reading	03, 04
1130	41131	AI7: Scaled Reading	03, 04
1131	41132	AI7: Scaled Reading	03, 04
1132	41133	AI8: Scaled Reading	03, 04
1133	41134	AI8: Scaled Reading	03, 04
1134	41135	DI1: Total Counts (Unsigned int, High Word)	03, 04
1135	41136	DI1: Total Counts (Unsigned int Low Word)	03, 04
1136	41137	DI2: Total Counts	03, 04
1137	41138	DI2: Total Counts	03, 04
1138	41139	DI3: Total Counts	03, 04
1139	41140	DI3: Total Counts	03, 04
1140	41141	DI4: Total Counts	03, 04
1141	41142	DI4: Total Counts	03, 04
1142	41143	DI5: Total Counts	03, 04
1143	41144	DI5: Total Counts	03, 04
1144	41145	DI6: Total Counts	03, 04
1145	41146	DI6: Total Counts	03, 04
1146	41147	Supply Voltage (mV)	03, 04
<i>Read/Write</i>			
1150	41151	DI Alarm Channel (0 = disabled, 1 – 6 = DI Channel)	03, 04, 06, 16
1151	41152	DI Alarm1 Channel (0 = disabled, 1 – 8 = AI Channel)	03, 04, 06, 16
1152	41153	DI Alarm1 Threshold (Unsigned int, Scaled or μ A/mV)	03, 04, 06, 16
1153	41154	DI Alarm2 Channel	03, 04, 06, 16
1154	41155	DI Alarm2 Threshold	03, 04, 06, 16
1155	41156	DI Alarm3 Channel	03, 04, 06, 16
1156	41157	DI Alarm3 Threshold	03, 04, 06, 16
1157	41158	DI Alarm4 Channel	03, 04, 06, 16
1158	41159	DI Alarm5 Threshold	03, 04, 06, 16
1159	41160	AI1: Scale Low (Signed int, Ex. 0 psi)	03, 04, 06, 16

1160	41161	AI1: Scaled High (Signed int, 3000 psi)	03, 04, 06, 16
1161	41162	AI2: Scale Low (both Low = 0 and High = 0 disables Scaling)	03, 04, 06, 16
1162	41163	AI2: Scale High	03, 04, 06, 16
1163	41164	AI3: Scale Low	03, 04, 06, 16
1164	41165	AI3: Scale High	03, 04, 06, 16
1165	41166	AI4: Scale Low	03, 04, 06, 16
1166	41167	AI4: Scale High	03, 04, 06, 16
1167	41168	AI5: Scale Low	03, 04, 06, 16
1168	41169	AI5: Scale High	03, 04, 06, 16
1169	41170	AI6: Scale Low	03, 04, 06, 16
1170	41171	AI6: Scale High	03, 04, 06, 16
1171	41172	AI7: Scale Low	03, 04, 06, 16
1172	41173	AI7: Scale High	03, 04, 06, 16
1173	41174	AI8: Scale Low	03, 04, 06, 16
1174	41175	AI8: Scale High	03, 04, 06, 16
1175	41176	Failsafe/Latch Enable (bit0 = Relay1 Failsafe, bit1 = Relay1 Latch)	03, 04, 06, 16
1176	41177	Comm. Failsafe Timer (0 = disabled, 1-255 = duration (minutes))	03, 04, 06, 16
1177	41178	Mesg. Failsafe Timer (0 = disabled, 1-255 = duration (minutes))	03, 04, 06, 16
1178	41179	Module Failsafe Timer (0 = disabled, 1-255 = duration (minutes))	03, 04, 06, 16
1179	41180	DI1 Debounce Time in mS (0 = disabled)	03, 04, 06, 16
1180	41181	DI2 Debounce Time in mS (0 = disabled)	03, 04, 06, 16
1181	41182	DI3 Debounce Time in mS (0 = disabled)	03, 04, 06, 16
1182	41183	DI4 Debounce Time in mS (0 = disabled)	03, 04, 06, 16
1183	41184	DI5 Debounce Time in mS (0 = disabled)	03, 04, 06, 16
1184	41185	DI6 Debounce Time in mS (0 = disabled)	03, 04, 06, 16
1185	41186	DI Alarm Override Relays (bit0 = Relay1, bit1 = Relay2)	03, 04, 06, 16
1186	41187	AI Alarm1 Override Relays (bit0 = Relay1, bit1 = Relay2)	03, 04, 06, 16
1187	41188	AI Alarm2 Override Relays (bit0 = Relay1, bit1 = Relay2)	03, 04, 06, 16
1188	41189	AI Alarm3 Override Relays (bit0 = Relay1, bit1 = Relay2)	03, 04, 06, 16
1189	41190	AI Alarm4 Override Relays (bit0 = Relay1, bit1 = Relay2)	03, 04, 06, 16

Register Address	Register Number	Description	Function Codes
Coils (0xxxx)			
<i>Write-only</i>			
201	00202	Relay1 Coil	05
202	00203	Relay2 Coil	05
203	00204	Relay3 Coil	05
204	00205	Relay4 Coil	05
211	00212	Counter1 Reset Coil	05
212	00213	Counter2 Reset Coil	05
213	00214	Counter3 Reset Coil	05
214	00215	Counter4 Reset Coil	05
215	00216	Counter5 Reset Coil	05
216	00217	Counter6 Reset Coil	05
231	00232	Relay1 Force Unlatch Coil	05
232	00233	Relay2 Force Unlatch Coil	05
233	00234	Relay3 Force Unlatch Coil	05
234	00235	Relay4 Force Unlatch Coil	05
Holding Registers			
<i>Write-only</i>			
221	40222	Relay1 Pulse (0 = Off, 1 – 255 = Pulse Time (sec))	06
222	40223	Relay2 Pulse	06
223	40224	Relay3 Pulse	06
224	40225	Relay4 Pulse	06
<i>Read-only</i>			
1200	41201	AI1: Current or Voltage Reading (Unsigned int, μ A or mV)	03, 04
1201	41202	AI2: Current or Voltage Reading	03, 04
1202	41203	AI3: Current or Voltage Reading	03, 04
1203	41204	AI4: Current or Voltage Reading	03, 04
1204	41205	AI5: Current or Voltage Reading	03, 04
1205	41206	AI6: Current or Voltage Reading	03, 04
1206	41207	AI7: Current or Voltage Reading	03, 04
1207	41208	AI8: Current or Voltage Reading	03, 04
1208	41209	DI1: State (Unsigned int, 1 = Closed or 0 = open)	03, 04
1209	41210	DI2: State	03, 04
1210	41211	DI3: State	03, 04
1211	41212	DI4: State	03, 04
1212	41213	DI5: State	03, 04
1213	41214	DI6: State	03, 04
1214	41215	Relay #1 State (Unsigned int, 1 = ON or 0 = OFF)	03, 04
1215	41216	Relay #2 State	03, 04

1216	41217	Relay #3 State	03, 04
1217	41218	Relay #4 State	03, 04
1218	41219	AI1: Scaled Reading (Float, High Word)	03, 04
1219	41220	AI1: Scaled Reading (Float, Low Word)	03, 04
1220	41221	AI2: Scaled Reading	03, 04
1221	41222	AI2: Scaled Reading	03, 04
1222	41223	AI3: Scaled Reading	03, 04
1223	41224	AI3: Scaled Reading	03, 04
1224	41225	AI4: Scaled Reading	03, 04
1225	41226	AI4: Scaled Reading	03, 04
1226	41227	AI5: Scaled Reading	03, 04
1227	41228	AI5: Scaled Reading	03, 04
1228	41229	AI6: Scaled Reading	03, 04
1229	41230	AI6: Scaled Reading	03, 04
1230	41231	AI7: Scaled Reading	03, 04
1231	41232	AI7: Scaled Reading	03, 04
1232	41233	AI8: Scaled Reading	03, 04
1233	41234	AI8: Scaled Reading	03, 04
1234	41235	DI1: Total Counts (Unsigned int, High Word)	03, 04
1235	41236	DI1: Total Counts (Unsigned int, Low Word)	03, 04
1236	41237	DI2: Total Counts	03, 04
1237	41238	DI2: Total Counts	03, 04
1238	41239	DI3: Total Counts	03, 04
1239	41240	DI3: Total Counts	03, 04
1240	41241	DI4: Total Counts	03, 04
1241	41242	DI4: Total Counts	03, 04
1242	41243	DI5: Total Counts	03, 04
1243	41244	DI5: Total Counts	03, 04
1244	41245	DI6: Total Counts	03, 04
1245	41246	DI6: Total Counts	03, 04
1246	41247	Supply Voltage (mV)	03, 04
<i>Read/Write</i>			
1250	41251	DI Alarm Channel (0 = disabled, 1 – 6 = DI Channel)	03, 04, 06, 16
1251	41252	AI Alarm1 Channel (0 = disabled, 1 – 8 = AI Channel)	03, 04, 06, 16
1252	41253	AI Alarm1 Threshold (Unsigned int, Scaled or μ A/mV)	03, 04, 06, 16
1253	41254	AI Alarm2 Channel	03, 04, 06, 16
1254	41255	AI Alarm2 Threshold	03, 04, 06, 16
1255	41256	AI Alarm3 Channel	03, 04, 06, 16
1256	41257	AI Alarm3 Threshold	03, 04, 06, 16
1257	41258	AI Alarm4 Channel	03, 04, 06, 16
1258	41259	AI Alarm4 Threshold	03, 04, 06, 16
1259	41260	AI1: Scale Low (Signed int, Ex. 0 psi)	03, 04, 06, 16

1260	41261	AI1: Scale High (Signed int, 3000 psi)	03, 04, 06, 16
1261	41262	AI2: Scale Low (both Low = 0 and High = 0 disables Scaling)	03, 04, 06, 16
1262	41263	AI2: Scale High	03, 04, 06, 16
1263	41264	AI3: Scale Low	03, 04, 06, 16
1264	41265	AI3: Scale High	03, 04, 06, 16
1265	41266	AI4: Scale Low	03, 04, 06, 16
1266	41267	AI4: Scale High	03, 04, 06, 16
1267	41268	AI5: Scale Low	03, 04, 06, 16
1268	41269	AI5: Scale High	03, 04, 06, 16
1269	41270	AI6: Scale Low	03, 04, 06, 16
1270	41271	AI6: Scale High	03, 04, 06, 16
1271	41272	AI7: Scale Low	03, 04, 06, 16
1272	41272	AI7: Scale High	03, 04, 06, 16
1273	41273	AI8: Scale Low	03, 04, 06, 16
1274	41274	AI8: Scale High	03, 04, 06, 16
1275	41276	Failsafe/Latch Enable (bit0 = Relay1 Failsafe, bit1 = Relay1 Latch)	03, 04, 06, 16
1276	41277	Comm. Failsafe Timer (0 = disabled, 1-255 = duration (minutes))	03, 04, 06, 16
1277	41278	Mesg. Failsafe Timer (0 = disabled, 1-255 duration (minutes))	03, 04, 06, 16
1278	41279	Module Failsafe Timer (0 = disabled, 1-255 = duration (minutes))	03, 04, 06, 16
1279	41280	DI1 Debounce Time in mS (0 = disabled)	03, 04, 06, 16
1280	41281	DI2 Debounce Time in mS (0 = disabled)	03, 04, 06, 16
1281	41282	DI3 Debounce Time in mS (0 = disabled)	03, 04, 06, 16
1282	41283	DI4 Debounce Time in mS (0 = disabled)	03, 04, 06, 16
1283	41284	DI5 Debounce Time in mS (0 = disabled)	03, 04, 06, 16
1284	41285	DI6 Debounce Time in mS (0 = disabled)	03, 04, 06, 16
1285	41286	DI Alarm Override Relays (bit0 = Relay1, bit1 = Relay2)	03, 04, 06, 16
1286	41287	AI Alarm1 Override Relays (bit0 = Relay1, bit1 = Relay2)	03, 04, 06, 16
1287	41288	AI Alarm2 Override Relays (bit0 = Relay1, bit1 = Relay2)	03, 04, 06, 16
1288	41289	AI Alarm3 Override Relays (bit0 = Relay1, bit1 = Relay2)	03, 04, 06, 16
1289	41290	AI Alarm4 Override Relays (bit0 = Relay1, bit1 = Relay2)	03, 04, 06, 16

Register Address	Register Number	Description	Function Codes
Coils (0xxxx)			
<i>Write-only</i>			
801	00802	Relay1 Coil	05
802	00803	Relay2 Coil	05
803	00804	Relay3 Coil	05
804	00805	Relay4 Coil	05
811	00812	Counter1 Reset Coil	05
812	00813	Counter2 Reset Coil	05
813	00814	Counter3 Reset Coil	05
814	00815	Counter4 Reset Coil	05
815	00816	Counter5 Reset Coil	05
816	00817	Counter6 Reset Coil	05
831	00832	Relay1 Force Unlatch Coil	05
832	00833	Relay2 Force Unlatch Coil	05
833	00834	Relay3 Force Unlatch Coil	05
834	00835	Relay4 Force Unlatch Coil	05
Holding Registers (4xxxx)			
<i>Write-only</i>			
821	40822	Relay1 Pulse (0 = Off, 1 – 255 = Pulse Time (sec))	06
822	40823	Relay2 Pulse	06
823	40824	Relay3 Pulse	06
824	40825	Relay4 Pulse	06
<i>Read-only</i>			
1800	41801	AI1: Current or Voltage Reading (Unsigned int, μ A or mV)	03, 04
1801	41802	AI2: Current or Voltage Reading	03, 04
1802	41803	AI3: Current or Voltage Reading	03, 04
1803	41804	AI4: Current or Voltage Reading	03, 04
1804	41805	AI5: Current or Voltage Reading	03, 04
1805	41806	AI6: Current or Voltage Reading	03, 04
1806	41807	AI7: Current or Voltage Reading	03, 04
1807	41808	AI8: Current or Voltage Reading	03, 04
1808	41809	DI1: State (Unsigned int, 1 = Closed or 0 = Open)	03, 04
1809	41810	DI2: State	03, 04
1810	41811	DI3: State	03, 04
1811	41812	DI4: State	03, 04
1812	41813	DI5: State	03, 04
1813	41814	DI6: State	03, 04
1814	41815	Relay #1 State (Unsigned int, 1 = ON or 0 = OFF)	03, 04
1815	41816	Relay #2 State	03, 04

1816	41817	Relay #3 State	03, 04
1817	41818	Relay #4 State	03, 04
1818	41819	AI1: Scaled Reading (Float, High Word)	03, 04
1819	41820	AI1: Scaled Reading (Float, Low Word)	03, 04
1820	41821	AI2: Scaled Reading	03, 04
1821	41822	AI2: Scaled Reading	03, 04
1822	41823	AI3: Scaled Reading	03, 04
1823	41824	AI3: Scaled Reading	03, 04
1824	41825	AI4: Scaled Reading	03, 04
1825	41826	AI4: Scaled Reading	03, 04
1826	41827	AI5: Scaled Reading	03, 04
1827	41828	AI5: Scaled Reading	03, 04
1828	41829	AI6: Scaled Reading	03, 04
1829	41830	AI6: Scaled Reading	03, 04
1830	41831	AI7: Scaled Reading	03, 04
1831	41832	AI7: Scaled Reading	03, 04
1832	41833	AI8: Scaled Reading	03, 04
1833	41834	AI8: Scaled Reading	03, 04
1834	41835	DI1: Total Counts (Unsigned int, High Word)	03, 04
1835	41836	DI1: Total Counts (Unsigned int, Low Word)	03, 04
1836	41837	DI2: Total Counts	03, 04
1837	41838	DI2: Total Counts	03, 04
1838	41839	DI3: Total Counts	03, 04
1839	41840	DI3: Total Counts	03, 04
1840	41841	DI4: Total Counts	03, 04
1841	41842	DI4: Total Counts	03, 04
1842	41843	DI5: Total Counts	03, 04
1843	41844	DI5: Total Counts	03, 04
1844	41845	DI6: Total Counts	03, 04
1845	41846	DI6: Total Counts	03, 04
1846	41847	Supply Voltage (mV)	03, 04
<i>Read/Write</i>			
1850	41851	DI Alarm Channel (0 = disabled, 1-6 = DI channel)	03, 04, 06, 16
1851	41852	AI Alarm1 Channel (0 = disabled, 1-8 = AI Channel)	03, 04, 06, 16
1852	41853	AI Alarm1 Threshold (Unsigned int, Scaled or μ A/mV)	03, 04, 06, 16
1853	41854	AI Alarm2 Channel	03, 04, 06, 16
1854	41855	AI Alarm2 Threshold	03, 04, 06, 16
1855	41856	AI Alarm3 Channel	03, 04, 06, 16
1856	41857	AI Alarm3 Threshold	03, 04, 05, 16
1857	41858	AI Alarm4 Channel	03, 04, 06, 16
1858	41859	AI Alarm4 Threshold	03, 04, 06, 16
1859	41860	AI1: Scale Low (Signed int, Ex. 0 psi)	03, 04, 06, 16

1860	41861	AI1: Scale High (Signed int, 3000 psi)	03, 04, 06, 16
1861	41862	AI2: Scale Low (both Low = 0 and High = 0 disables Scaling)	03, 04, 06, 16
1862	41863	AI2: Scale High	03, 04, 06, 16
1863	41864	AI3: Scale Low	03, 04, 06, 16
1864	41865	AI3: Scale High	03, 04, 06, 16
1865	41866	AI4: Scale Low	03, 04, 06, 16
1866	41867	AI4: Scale High	03, 04, 06, 16
1867	41868	AI5: Scale Low	03, 04, 06, 16
1868	41869	AI5: Scale High	03, 04, 06, 16
1869	41870	AI6: Scale Low	03, 04, 06, 16
1870	41871	AI6: Scale High	03, 04, 06, 16
1871	41872	AI7: Scale Low	03, 04, 06, 16
1872	41873	AI7: Scale High	03, 04, 06, 16
1873	41874	AI8: Scale Low	03, 04, 06, 16
1874	41875	AI8: Scale High	03, 04, 06, 16
1875	41876	Failsafe/Latch Enable (bit0 = Relay1 Failsafe, bit1 = Relay1 Latch)	03, 04, 06, 16
1876	41877	Comm. Failsafe Timer (0 = disabled, 1-255 = duration (minutes))	03, 04, 06, 16
1877	41878	Mesg. Failsafe Timer (0 = disabled, 1-255 = duration (minutes))	03, 04, 06, 16
1878	41879	Module Failsafe Timer (0 = disabled, 1-255 = duration (minutes))	03, 04, 06, 16
1879	41880	DI1 Debounce Time in mS (0 = disabled)	03, 04, 06, 16
1880	41881	DI2 Debounce Time in mS (0 = disabled)	03, 04, 06, 16
1881	41882	DI3 Debounce Time in mS (0 = disabled)	03, 04, 06, 16
1882	41883	DI4 Debounce Time in mS (0 = disabled)	03, 04, 06, 16
1883	41884	DI5 Debounce Time in mS (0 = disabled)	03, 04, 06, 16
1884	41885	DI6 Debounce Time in mS (0 = disabled)	03, 04, 06, 16
1885	41886	DI Alarm Override Relays (bit0 = Relay1, bit1 = Relay2)	03, 04, 06, 16
1886	41887	AI Alarm1 Override Relays (bit0 = Relay1, bit1 = Relay2)	03, 04, 06, 16
1887	41888	AI Alarm2 Override Relays (bit0 = Relay1, bit1 = Relay2)	03, 04, 06, 16
1888	41889	AI Alarm3 Override Relays (bit0 = Relay1, bit1 = Relay2)	03, 04, 06, 16
1889	41890	AI Alarm4 Override Relays (bit0 = Relay1, bit1 = Relay2)	03, 04, 06, 16