

# RANGER WALL MOUNT

Sensor to Cloud Platform

PLUG-&-PLAY, INSTANT CONNECTIVITY OF A SENSOR TO THE CLOUD OVER CELLULAR NETWORKS

OPTIMIZED FOR BATTERY LIFE USING LATEST CELL MODEM TECHNOLOGY LTE CAT M1 / NB-IOT

MULTI INPUT/OUTPUT TO CONNECT TO A VARIETY OF SENSORS INCLUDING ANALOG, HART, SDI-12, AND MODBUS

MQTT & SPARKPLUG READY TO INTEGRATE WITH HOSTS OTHER THAN SIGNALFIRE CLOUD



## FEATURES

- LTE CAT M1 / NB-IoT connectivity to cloud services
- Integrated inputs/output for multi-sensors
- Data location from built-in GPS
- SignalFire cloud monitoring/alarming service
- Powers sensors from battery or external solar

## PRODUCT OVERVIEW

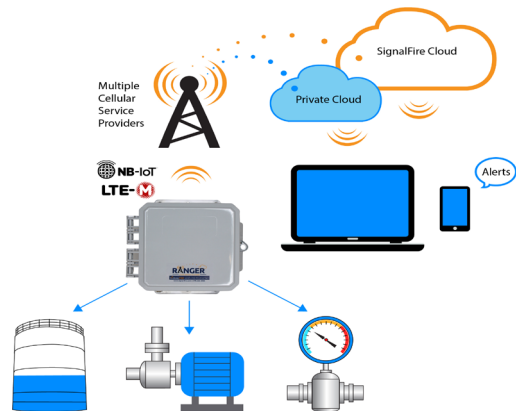

The SignalFire RANGER is an IoT (internet of things) cellular transmitter utilizing LTE-M/NB-IoT technology to bring sensor data directly to the cloud. Data is transmitted over cellular networks using the MQTT/Sparkplug protocol directly to the SignalFire Cloud for a complete monitoring and alarming service or can easily be integrated into a customer's existing system.

The built-in RANGER I/O consists of two (2) digital inputs, one (1) analog input and one (1) relay output. The digital inputs can detect on/off status or frequencies up to 2kHz for pulse counting and totalizing applications. The analog input supports a 1-5Vdc or 4-20mA device and provides power to the sensor from the built-in battery pack. The relay output is a latching single pole single to provide on/off control to a local device.

In addition to the built-in I/O the RANGER supports an optional expansion modules to support additional sensor types including Modbus, HART, SDI-12, and additional analog and digital inputs.

The RANGER comes complete with the mobile device ready SignalFire Cloud interface to monitor, trend and receive alarms either by text or email message. In addition, the cloud platform provides for remote configuration and troubleshooting of the RANGER node and its attached sensor(s) and the relay output may be controlled from the cloud interface to remotely control pumps, motors, and valves.

# RANGER WALL MOUNT

Sensor to Cloud Platform

## TECHNICAL SPECIFICATIONS

**Operating Temp:** -40 to 185°F (-40 to 85°C)

**Humidity:** 0% - 100% condensing

**Input Power:**

- Battery Pack: Four D-cell Lithium Thionyl Chloride, 76Ahr
- Optional solar power
- Optional 10-30Vdc input. Average Current at 12VDC: 20mA (without attached sensors), 110mA with maximum 60mA sensor load. Peak current 250mA

**Input/Output:**

Standard

- 1 Latching Relay Output (2A @ 30Vdc; 0.3A @ 110Vac; 0.5A @ 125Vac). Failsafe & local automation configurable
- 2 Digital Inputs report state, total counts, frequency (2kHz max), volume total with K Factor, daily runtime operations in seconds
- Analog Input (4-20mA, 1-5V, 0-5V, 0-10V, 0-15V and 0.5-2.5V). Configurable for flow totalizing mode
- Provides a configurable 13V or 18V to attached sensor(s). Max. current of 60mA.

Expansion Module Options:

(one module possible per RANGER)

**2AI1DI Module:**

- Adds 2 additional analog inputs and 1 additional digital input

**Modbus Module:**

- Modbus RTU - RS485 up to 8 slaves, 32 total registers (read/write) .96 optional

**HART Module:**

- Supports 1-15 HART sensors in multi-drop mode
- Reports 4 process variables, field device status, unique identifier and device tag for each HART device
- Scan and configure HART IDs with the Ranger, separate HART modem not required

**SDI-12 Module:**

- Monitors and powers one to eight SDI-12 sensors at 13V, 60mA max
- Reads/reports up to 16 measurements
- Supports reading the default and all additional measurements from connected SDI-12 devices

**Battery Life:** Up to 8 years

**Data Interface:**

- LTE CAT M1 / NB-IoT, auto-selectable
- SparkPlug messaging

**Cellular Radio Power:** 23dBm

**Antenna Type:** LTE w/ Internal GPS

**Enclosure:**

- **Material:** Industrial polycarbonate UV Rated
- **Environmental Protection Rating:** IP68 (6' for 24 hours)

**Safety Rating:** Class 1 Division 2 Certified, Groups A, B, C, D. Temperature Code T5. Certified to CSA C22.2 No. 213:2017, Conforms to UL 121201:2017, CE Approved

**FIRSTNet Capable Designation:** Certified by AT&T as a FIRSTNet-approved device for America's first responders and extended public safety community

**Electrical Connection:** Pluggable terminal block, 16-30AWG screw terminals

**Local Micro-USB Configuration Port**

**Weight:** 2 lbs, 15oz

**Estimated Monthly Data Usage:**

Check-in interval dependent

- 1 min = 27 MB
- 5 min = 5.4 MB
- 15 min = 1.08 MB
- 60 min = 0.27 MB

**Cellular Specifications:**

- LTE band support: Cat-M1 / NB-IoT: B1, B2, B3, B4, B5, B8, B12, B13, B14, B17, B20, B25, B26, B28, B66
- Supports 4FF SIM type
- Power saving features: eDRX
- Secure socket using TLS
- PTCRB Certified

# RANGER WALL MOUNT

Sensor to Cloud Platform

## DIMENSIONS

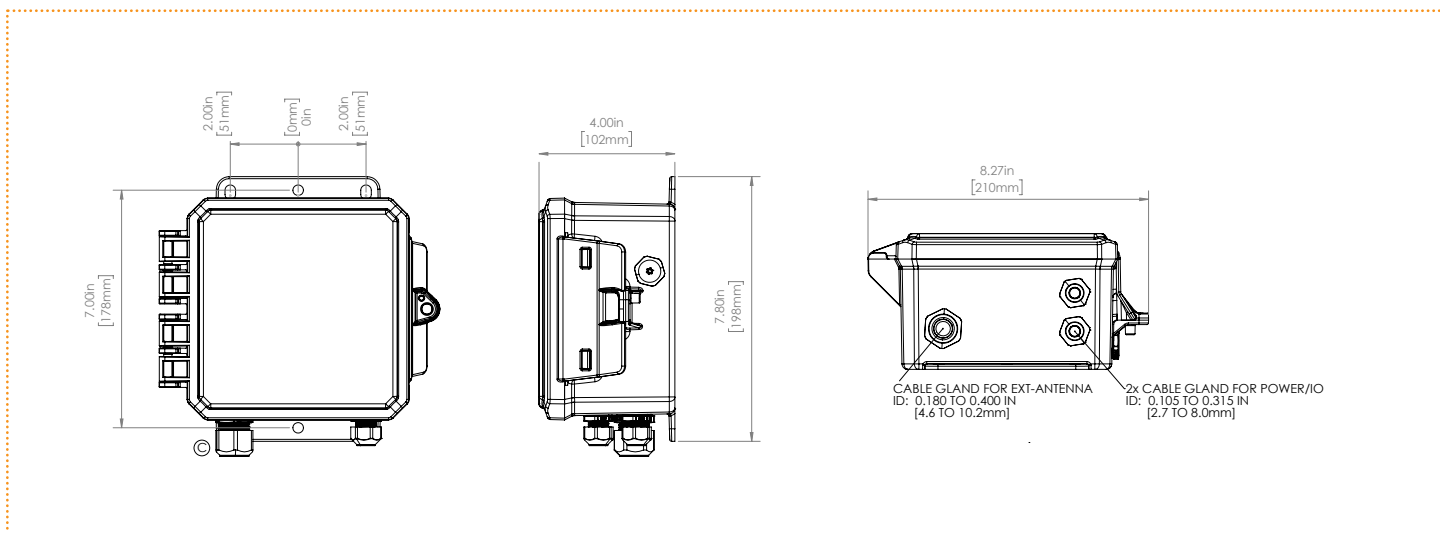

# RANGER WALL MOUNT

Sensor to Cloud Platform

## HOW TO ORDER

