

RANGER Wall Mount Manual

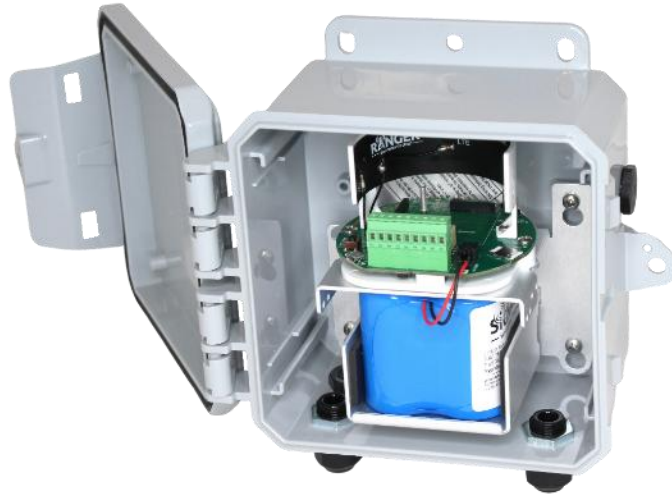

The RANGER Wall Mount version is designed to allow for wall mount installations and to provide environmental protection for the RANGER

- Dual digital inputs report state, total counts, and input frequency. K-Factor configurable for Flow Totalizing
- SPDT Latching relay for local on/off control
- Configurable from the SignalFire Cloud website signal-fire.cloud
- SignalFire Cloud allows for data visualization, trending, and alarming
- Supports MQTT Sparkplug B communication protocol for connection to other servers
- Compact and simple to install and maintain
- Local configuration and diagnostics available using the micro-USB port and the SignalFire RANGER ToolKit PC software
- Expansion modules for additional I/O (2AI/1DI, Modbus, HART, SDI-12)
- Internal backlog of a minimum of 200,000 datapoints in the event of loss of signal. Backlog will be automatically sent when the RANGER reconnects
- Can be field converted to support an external antenna
- Class 1 Division 2 certified

Specifications

Enclosure	Material: Industrial Polycarbonate UV Rated 7.8" tall × 8.27" wide x 4" deep Environmental Protection Rating: IP68 (6' for 24 hours) Weight: 2.1Lbs (1kg)
Input Power	Battery Pack: Four D-cell Lithium Thionyl Chloride, 76Ahr Optional solar power (C1D2) Optional 10-30Vdc input. Average Current at 12VDC: 20mA (without attached sensors), 110mA with maximum 60mA sensor load. Peak current 250mA
Temperature Rating	-40°F to +185°F (-40°C to 85°C) Humidity 0-100% condensing
RANGER SIM Slot	4FF Nano SIM card (LTE Cat M SIM and data plan required)
RANGER Local config port	Standard micro-USB connector
RANGER Analog Input	Provides 13Vdc/18Vdc, (selectable) to attached 4-20mA / 1-5Vdc sensor. One analog input built in. Up to three with additional 2AI/1DI module.
RANGER Digital Inputs	Two digital inputs. Three with additional 2AI/1DI module. Dry Contact or 30 Volts Max (push-pull), 2kHz max. Capable of reporting on state change
RANGER Relay Output	Latching Relay. 2A @ 30VDC, 0.3A @ 110VDC, 0.5A @ 125VAC
RANGER Sensor Power Output	Selectable 13Vdc / 18Vdc. 60mA max power output
Compliance	<ul style="list-style-type: none"> • Contains FCC ID: 2ANPO00NRF9160 and IC ID: 24529-NRF9160 • PTCRB and Verizon Network Certified • Certified for use in Class I, Division 2, Groups A, B, C, D areas. Temperature Code T5 EXi [EXi] • [UL 121201:2017 Ed.9+R:26Aug2019], [CSA C22.2#213:2017 Ed.3+U1;U2] • IEC 62638-1:2014 (2nd Ed), EN 62368-1:2014+A11:2017

HOW TO ORDER

RANGER LTE M1 Transmitter

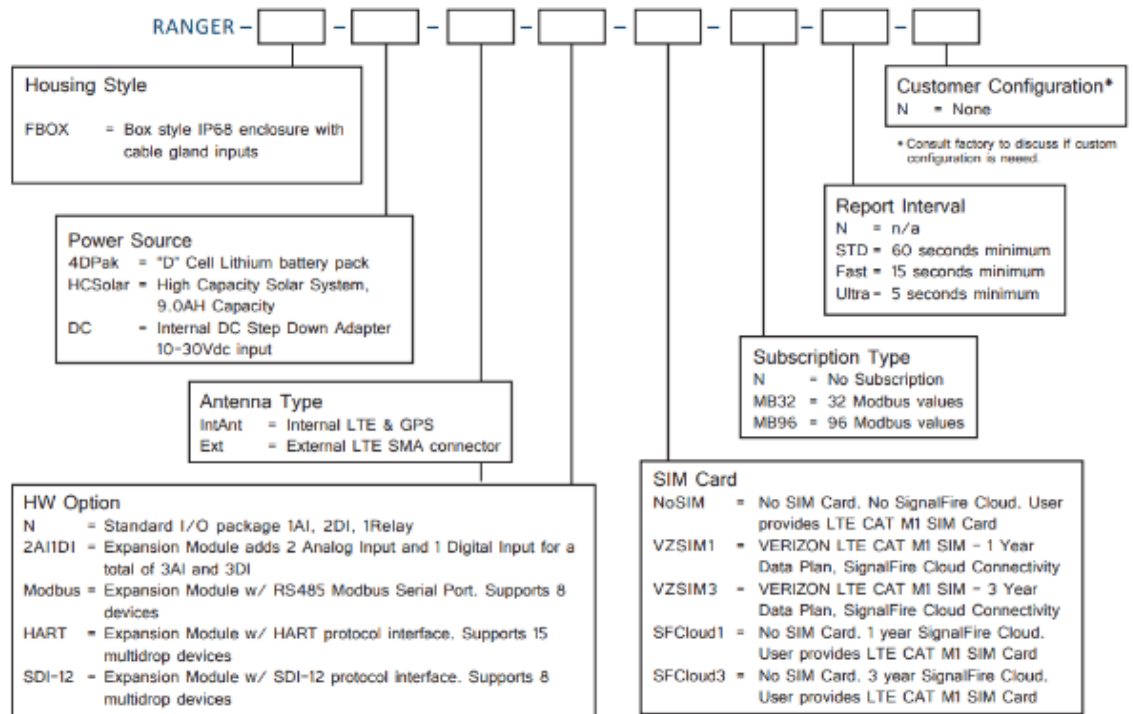

Table of Contents

Specifications	2
Table of Contents	4
Hazardous Location Certification	5
Dimensions.....	6
Connections and Components.....	7
Sensor Connections.....	8
Analog Input.....	8
Digital Inputs	9
Relay Output	10
2AI/1DI	11
Modbus RS-485	12
HART.....	13
SDI-12	14
RTD.....	15
Power Options	16
Lithium Battery Pack (4DPak).....	16
DC-DC converter	16
HC-Solar System.....	16
Internal Lithium Battery Replacement.....	16
Mounting and Care	17
External Antenna Conversion	18
Cloud Setup and Information.....	20
Technical Support and Contact Information.....	21
Revision History	21

Hazardous Location Certification

The RANGER is rated Class 1 Division 2 non-incendive when powered by its internal battery pack or its internal DC-DC converter. The HCSolar unit is not C1D2 certified so it is for general purpose areas only.



WARNING: EXPLOSION HAZARD. DO NOT REMOVE OR REPLACE COMPONENTS UNLESS POWER HAS BEEN DISCONNECTED OR THE AREA IS FREE OF IGNITIBLE CONCENTRATIONS.
 AVERTISSEMENT : RISQUE D'EXPLOSION . NE PAS RETIRER OU REMPLACER LES COMPOSANTS QUE L'ALIMENTATION EST DÉBRANCHÉ OU ZONE EST LIBRE DE CONCENTRATIONS IGNITIBLE.



WARNING – EXPLOSION HAZARD Substitution of components may impair suitability for Class I, Division 2

AVERTISSEMENT - RISQUE D'EXPLOSION. La substitution de composants peut rendre ce matériel inacceptable pour les emplacements de classe I, division 2



WARNING – EXPLOSION HAZARD Do not disconnect while circuit is live unless area is known to be nonhazardous

AVERTISSEMENT - RISQUE D'EXPLOSION. Ne débranchez pas lorsque le circuit est en direct , sauf si la zone est connue pour être nonhazardous



WARNING – All wiring methods must be in accordance with the NEC

AVERTISSEMENT - Toutes les méthodes de Essorez doivent être en conformité avec la NEC



WARNING - EXPLOSION HAZARD. Do no remove or replace while circuit is live unless the area is free of ignitable concentrations.

AVERTISSEMENT - RISQUE D'EXPLOSION. Ne pas enlever ou remplacer pendant que le circuit est vivant à moins que la zone soit exempt de concentrations ignitibles.



WARNING – EXPLOSION HAZARD. Do not remove or replace lamps, fuses, or plug-in modules (as applicable) unless power has been disconnected or the area is free of ignitable concentrations.

AVERTISSEMENT - RISQUE D'EXPLOSION. Ne retirez ni ne remplacez les lampes, les fusibles ou les modules enfichables (le cas échéant) à moins que l'alimentation ait été coupée ou que la zone soit exempte de concentrations inflammables.

Dimensions

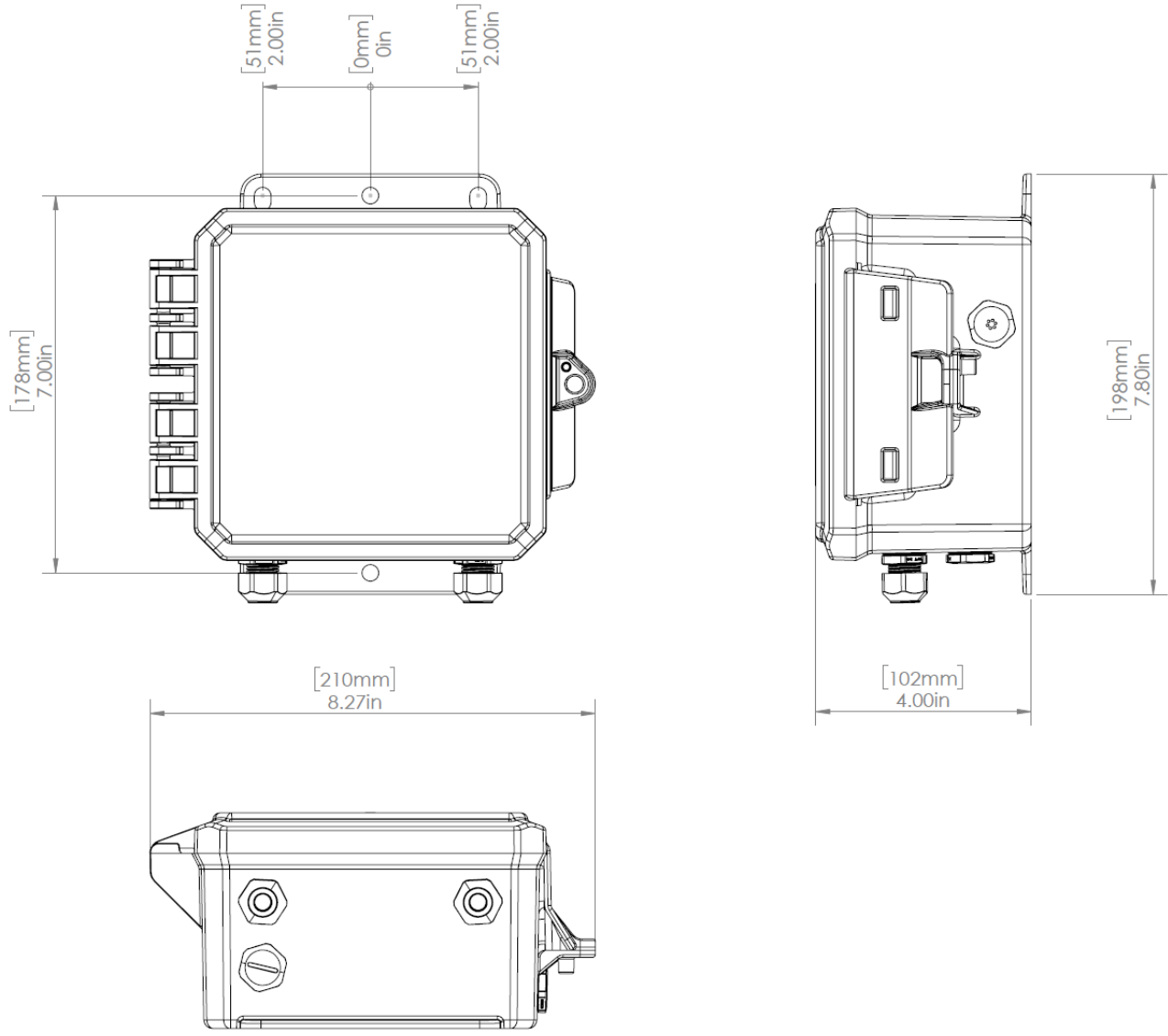

Connections and Components

STATUS LED

- The STATUS LED (green) will flash 3 times on a successful data transmission to the server

ERROR LED

- The ERROR LED (red) will blink 3 times to indicate that an attempted data transmission failed

Check-in Button

- If this button is pressed the RANGER will blink the green or red status LED 3 times to indicate the status of the last transmission to the server. If the Checkin button is pressed and held for more than 1 second, the RANGER will take readings from the attached sensors and send the readings to the server.

SignalFire Expansion Module

- The SignalFire Expansion Module slot is used for additional sensor support. Available expansion cards are 2AI/1DI, Modbus, and HART.

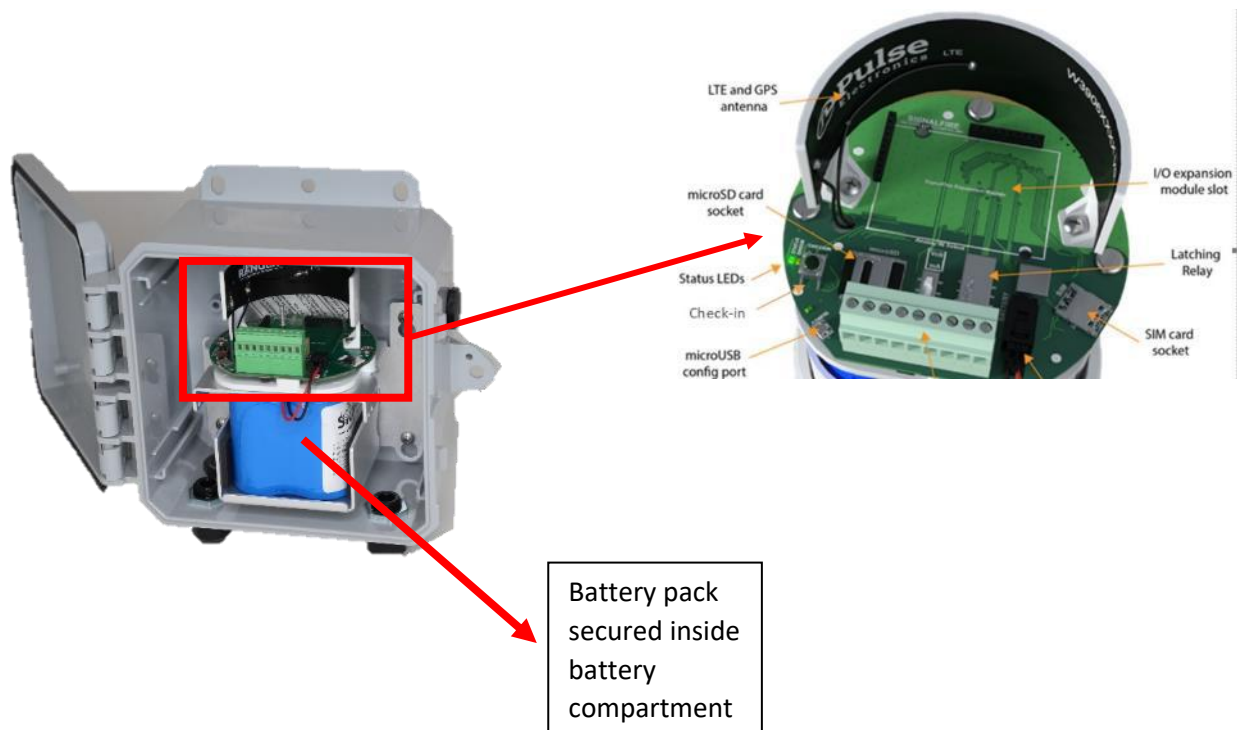

RANGER Internal components

Sensor Connections

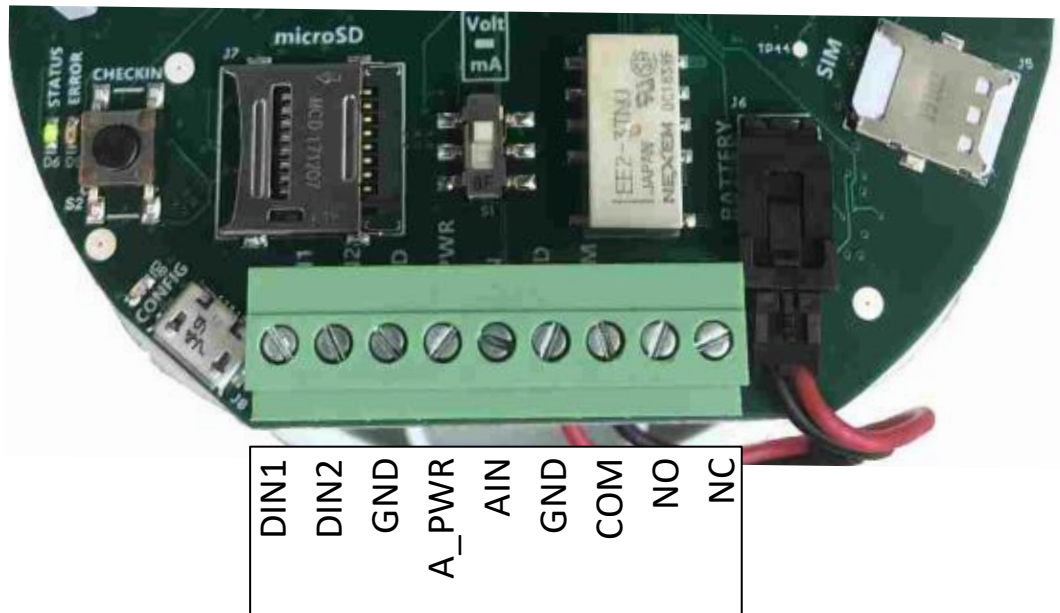

Screw Terminal Connections

Analog Input

The analog input provides 13V/18V (selectable in software, see page 11) to the attached sensor. The analog input can operate in either current (4-20mA), or voltage (1-5V). The input mode must be set by the slide switch. Slide the switch up to **Volts** for a voltage input, or down to **mA** for a current input.

4-20mA Wiring Diagram

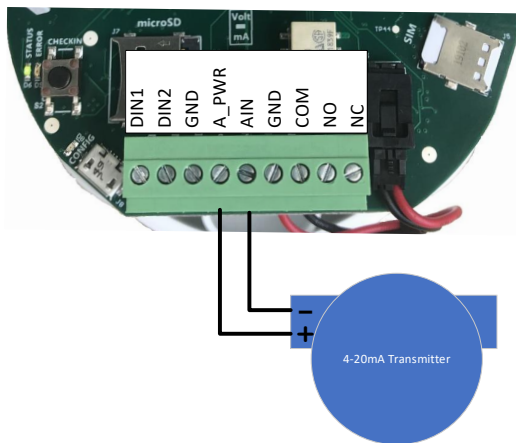

Sensor powered by RANGER

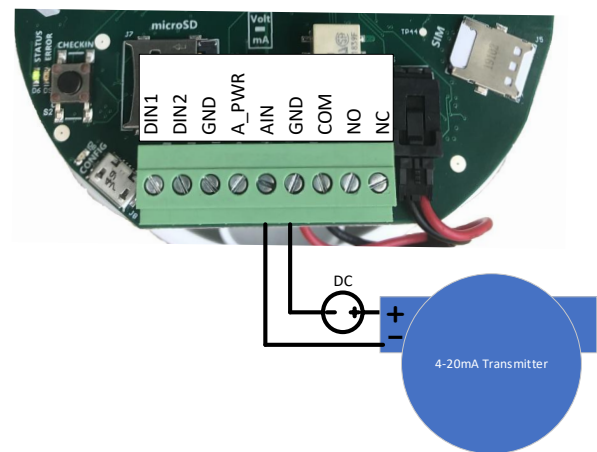

Sensor powered by external source

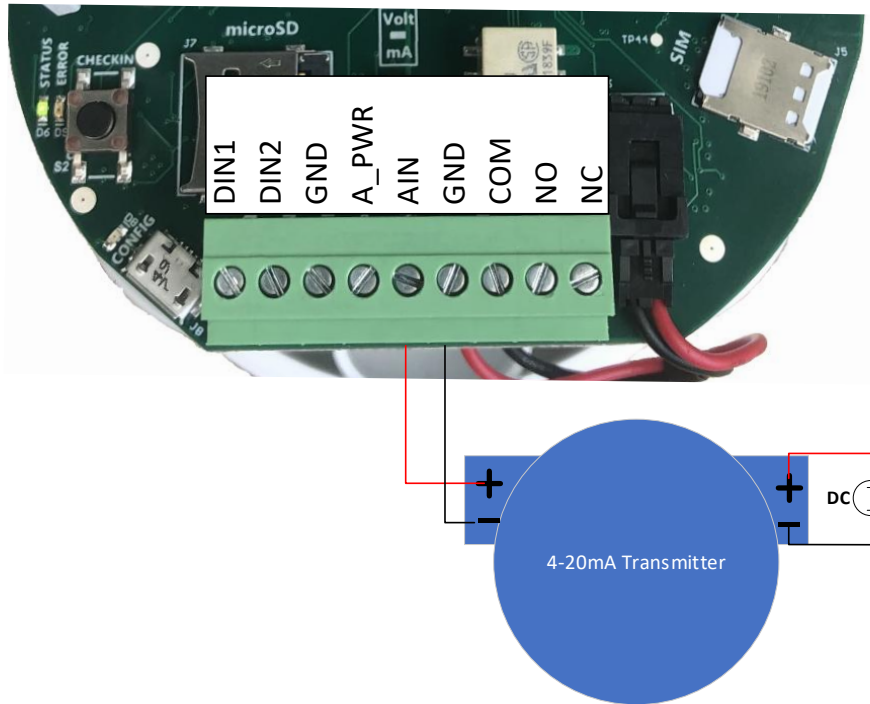

Sensor powered by Active Loop

1-5V Wiring Diagram

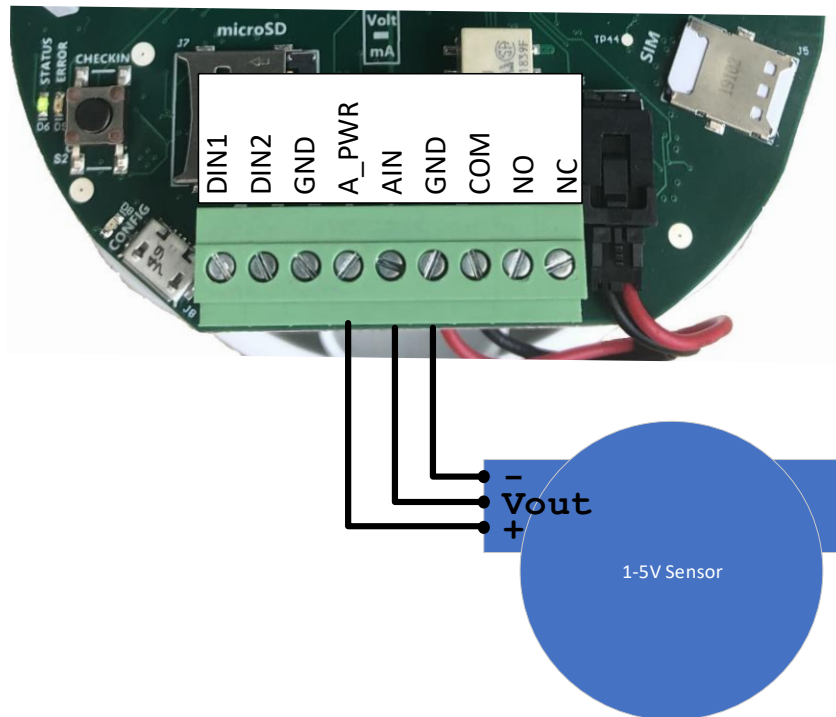

Digital Inputs

The digital inputs (2 total) can be dry contact or voltage (must be push-pull, 30Vdc max). Be sure to connect the ground bus from the module to either the ground of the voltage pulse device or the dry contact.

Relay Output

The RANGER has a single latching SPDT relay which may be controlled remotely from the server or by using the RANGER's internal relay control logic. The Relay will connect the COM terminal to NC when de-energized and the COM will be connected to the NO terminal when energized

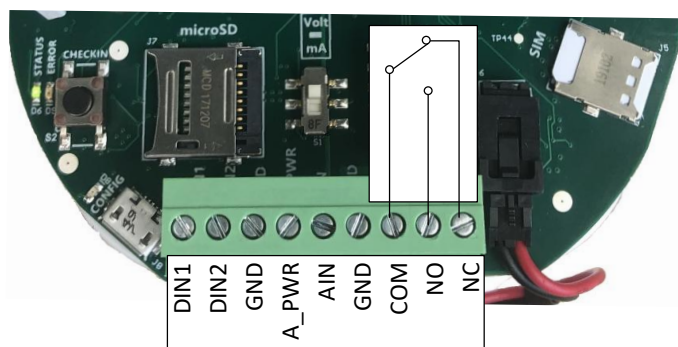

Relay Energized (COM connected to NC)

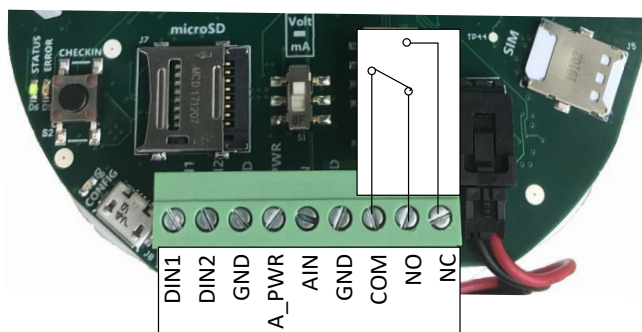

Relay De-Energized (COM connected to NO)

Expansion Cards

The RANGER has the option of being ordered with daughter cards to expand the I/O capabilities. Currently, four expansion cards are offered: the 2AI/1DI, Modbus, HART, RTD and SDI-12 cards. If the expansion cards are installed separately it must be enabled using the RANGER ToolKit by loading the appropriate firmware.

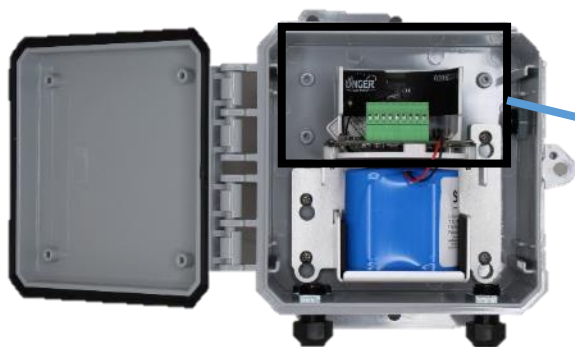

RANGER with a 2AI/1DI installed

2AI/1DI

The 2AI/1DI card provides the RANGER with two (2) additional analog inputs, and one (1) additional digital input.

These inputs operate the same as the analog and digital inputs of the base model. The analog inputs can be set to 4-20mA mode or 1-5Vdc mode via onboard switches. When installed, additional input configuration tiles will become available on the unit's SignalFire Cloud configuration page. An optional junction box provides for easy wiring to multiple sensors.

Modbus RS-485

The Modbus card provides the RANGER with the ability to read a Modbus sensor over two-wire RS-485. Follow the diagram below for wiring the Modbus expansion card to a sensor. Sensors can be powered off the RANGER's onboard analog sensor power output. Like the analog sensor, its voltage is set in the RANGER configuration tile (see page 11). The RANGER can provide up to a total of 60mA at 18Vdc for all attached sensors. If more power is needed, or to conserve battery life, it is recommended the sensors be powered with an external DC source. Follow the wiring diagram below for integrated and externally powered options.

The attached sensors need to each have a unique Modbus ID.

RS-485 Wiring Diagram

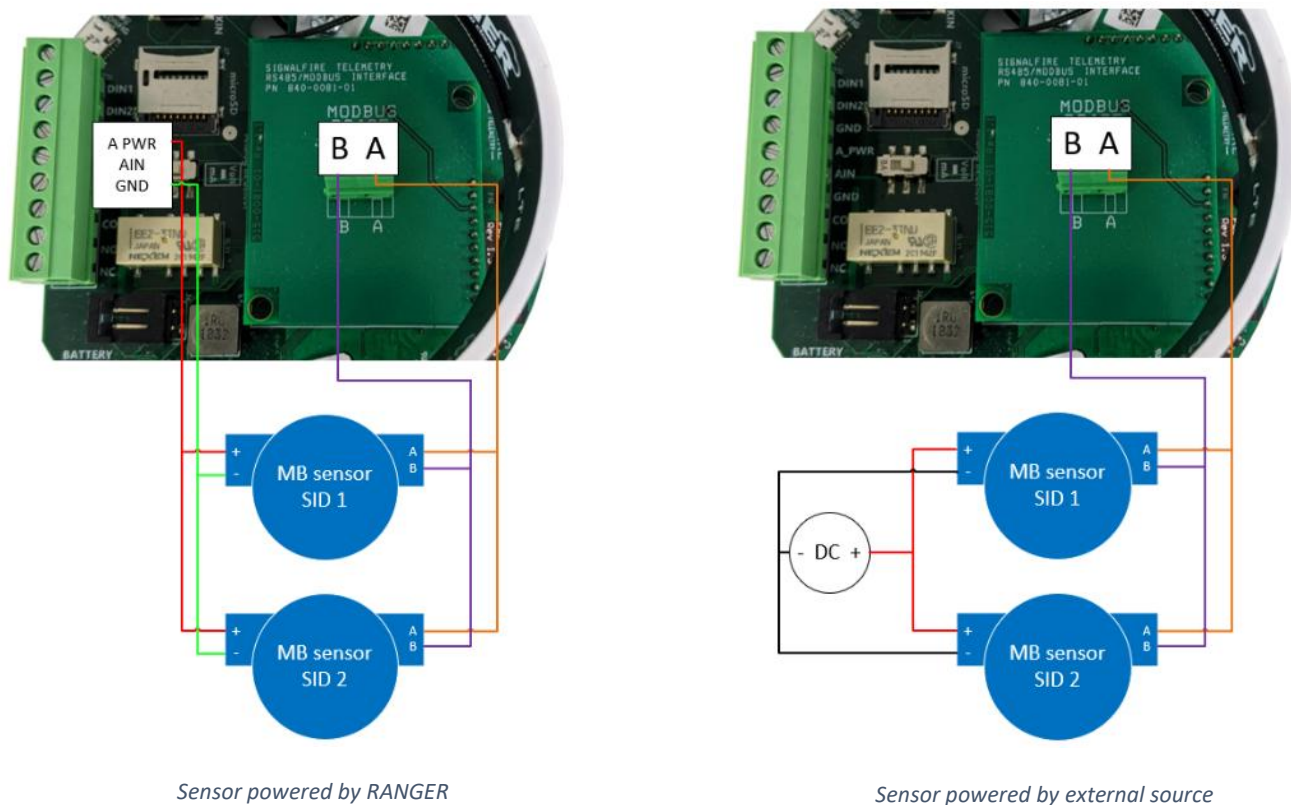

HART

The HART card provides the RANGER with the ability to power a HART transmitter and read its variables. The HART sensor should be wired to the RANGER's HART terminals as shown below. Note that the HART card also has 1 digital input available.

The system can supply up to 18Vdc to the sensors and then read the HART data from each sensor. Due to the 250 Ω series resistance, every additional sensor will draw 4mA in multi-drop mode, dropping the output voltage by 1Vdc. For example, if 4 HART devices are connected the total loop current will be 16mA, resulting in 4Vdc being dropped across the 250 Ω load resistor in the SignalFire node. If the RANGER is configured to output 18Vdc, this leaves 14V available to power the sensors.

If using an external power source, remove the jumper from the HART card. It is recommended to place a 250 Ω resistor in series with the source unless the supply already has a series resistor, to ensure proper HART communication across the bus. It is up to the operator to ensure that the resulting voltage of the source minus the drop across the series resistor meets the minimum voltage requirements of all attached sensors.

The attached sensors need to each have a unique HART ID. If their ID's have not been set up before connecting, they can be set up through the RANGER ToolKit.

HART Wiring Diagram

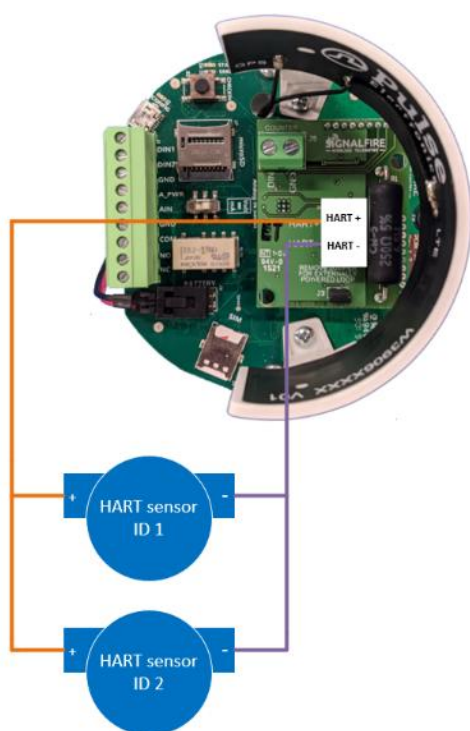

*Sensor powered by RANGER.
Jumper is on.*

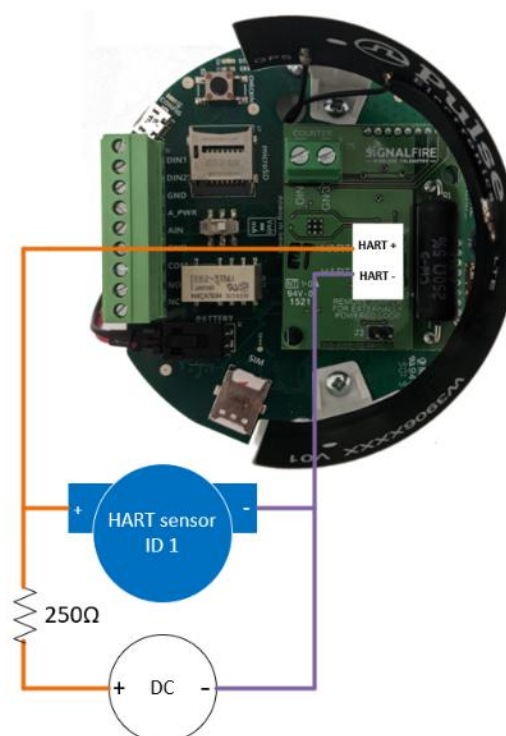

*Sensor powered by external source.
Jumper is off.*

SDI-12

The SDI-12 card provides the RANGER with the ability to read from SDI-12 sensors. The SDI-12 bus contains three lines, Power (12Vdc), Data, and GND. Across multiple sensors, these three lines must be connected in parallel, such that all the Power lines are connected together, the Data lines are all connected together, and GND lines are connected together.

If the RANGER is powering the sensors, it can provide up to 60mA at 12Vdc for all attached sensors. It is up to the operator to ensure this limit is not exceeded. If the sensors are powered externally, the Power terminal of the SDI-12 card must still be connected to the positive power terminal of each sensor and the external voltage source.

The attached sensors need to each have their own unique SDI-12 ID. If their ID's have not been set up before connecting, they can be set up through the RANGER ToolKit.

SDI-12 Wiring Diagram

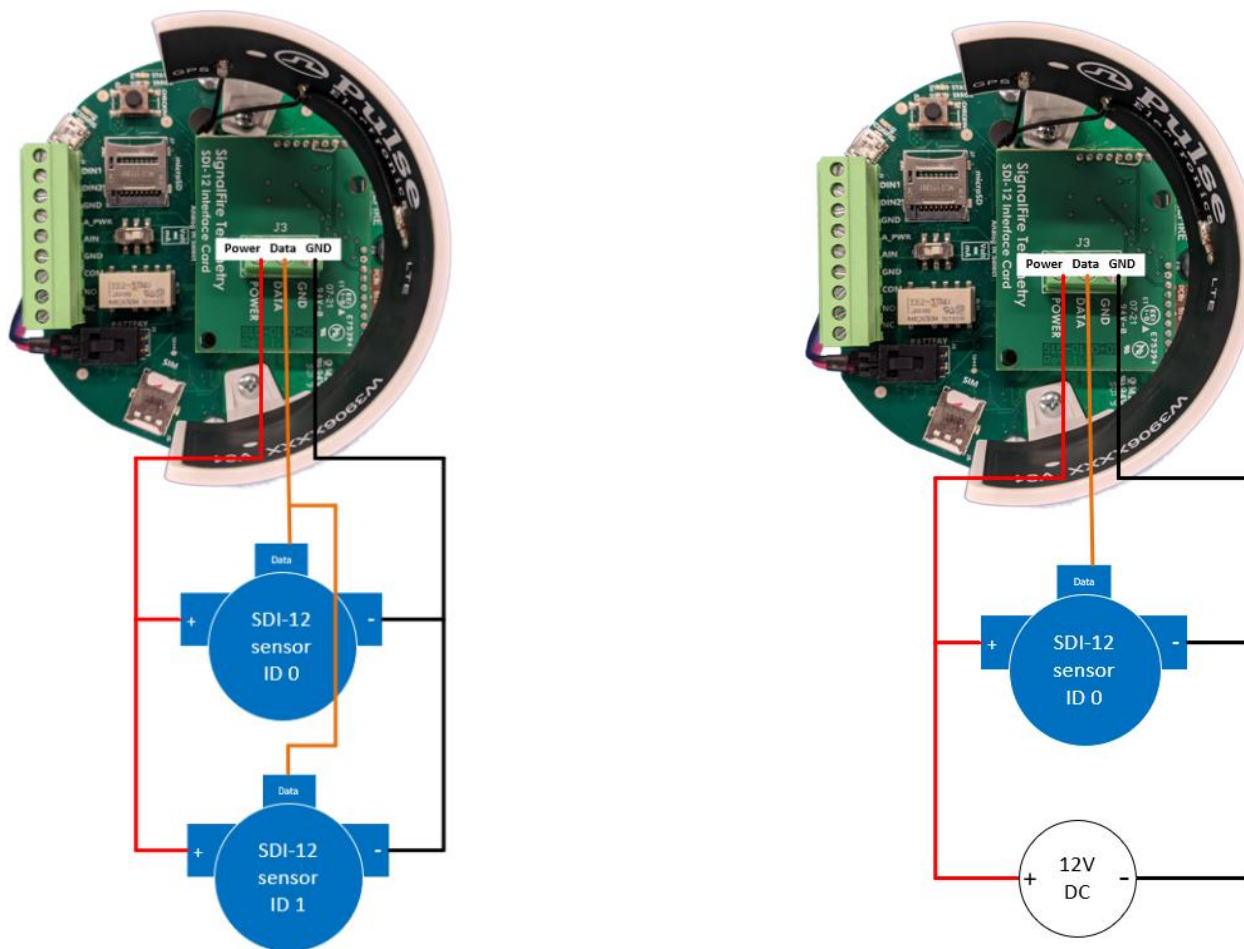

Sensor powered by RANGER

Sensor powered by external power supply. Positive terminals connected

RTD

The RTD card supports a direct connection to a 3-wire P100 RTD temperature probe. The RTD should be wired as pictured below.

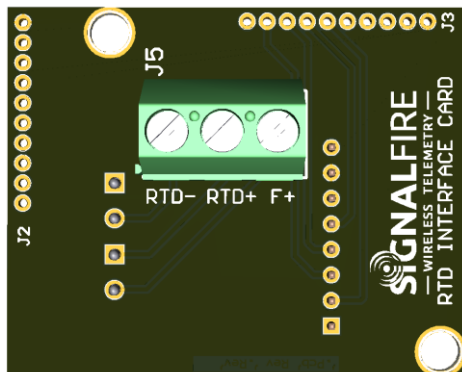

RANGER RTD Daughter Card

The F+ and RTD+ terminals should be wired to the two wires with the same color from the RTD (typically red), while the RTD- should be connected to the third RTD wire (typically white).

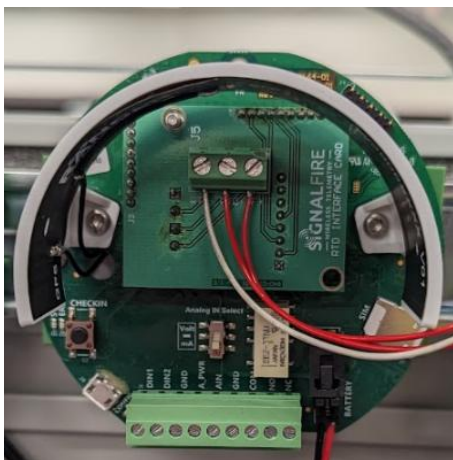

3 wire RTD

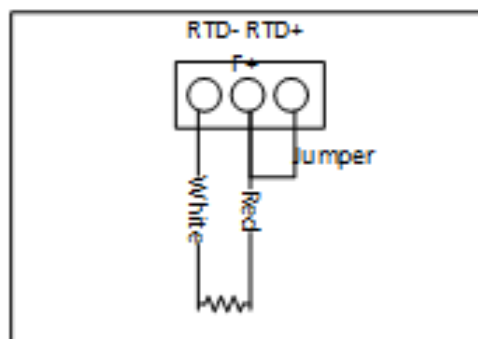

2 wire RTD

Power Options

Lithium Battery Pack (4DPak)

The internal lithium battery pack is the default power source for the ranger, simply plug the battery pack into the RANGER PCB battery connector to power the RANGER on.

DC-DC converter

In situations where DC power is available, the RANGER can be ordered with an internal DC-DC converter that accepts 9-36Vdc from an external source. The DC-DC converter is installed in the battery compartment of the RANGER and has a pigtail cable to connect to the RANGER PCB. Simply connect your DC power source to the "GND" and "Vin" screw terminals on the converter to power on the system.

HC-Solar System

SignalFire offers a solar system that consists of a bracket containing a solar panel and integrated battery and solar charger assembly. The solar system is connected to the RANGER PCB using the battery connector.

Internal Lithium Battery Replacement

Battery Packs can be changed with the node in place.

1. Unplug the battery from the PCB, by depressing the locking clip on the connector.
2. Push up on the top metal plate to allow you to remove and replace the battery
3. Connect the battery to the main PCB battery connector.

Mounting and Care

It is important to mount the RANGER, so it is vertically oriented with the NPT fitting facing down.

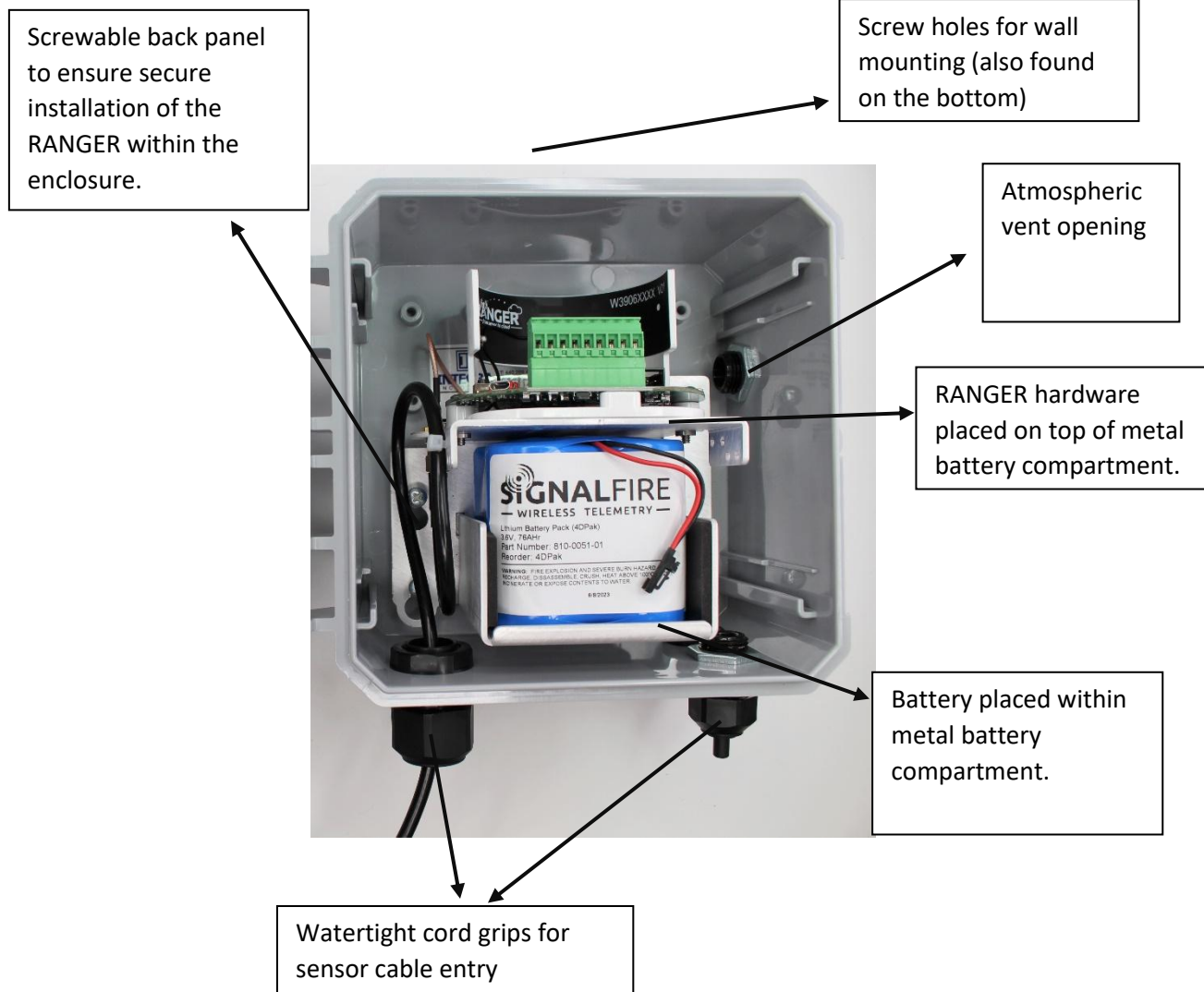

External Antenna Conversion

The Wall Mount RANGER is shipped with its internal antenna connected to the cellular modem. If an external antenna is needed the user can switch to the external antenna by following the following steps.

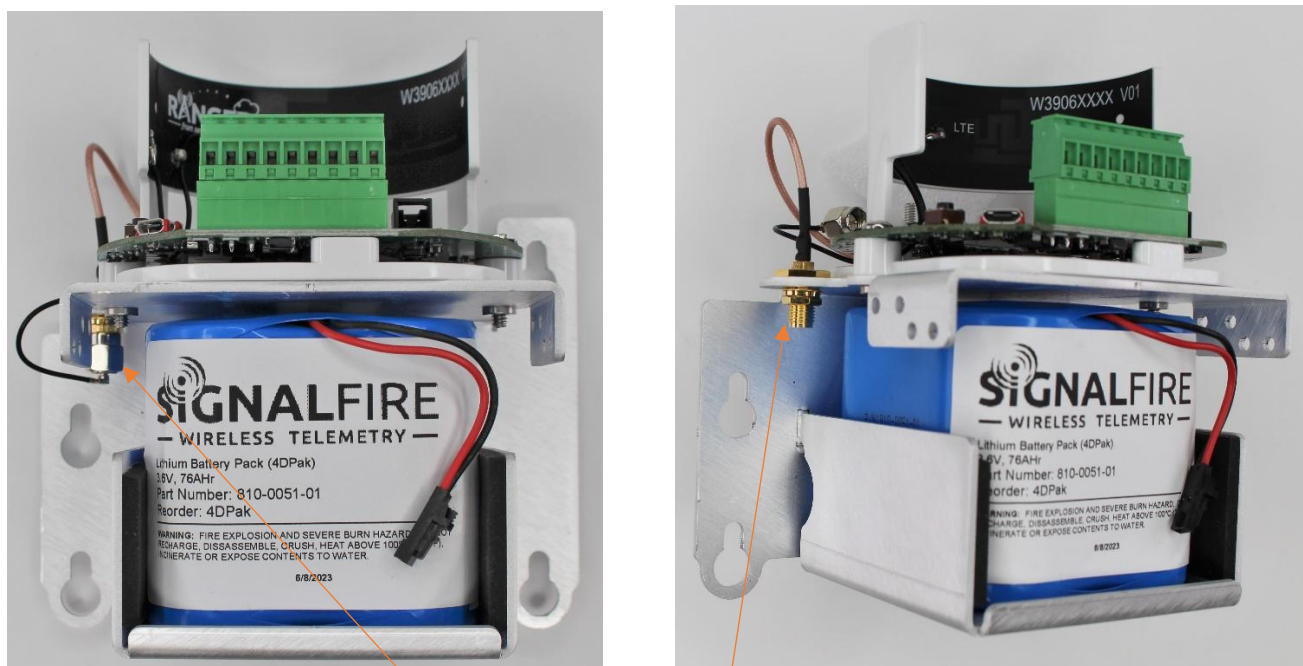

Disconnect the internal antenna connector by unscrewing the SMA connection. The antenna does not need to be removed. Tuck the connector in the back of the box.



Ensure that all cord grips are tight to provide a watertight seal.

Cloud Setup and Information

Full documentation on using the SignalFire Cloud features and how to remotely configure your RANGER is available in an online knowledge base. The manual provides instructions on user management, configuring alarms, generating reports, and more. Whether you are a new or experienced user, this manual serves as a valuable resource to maximize the platform's capabilities.

<https://www.signal-fire.com/cloud-manual/>

[Link to SF Cloud](#)

[Link to SF Cloud
Account Creation](#)

Devices purchased with the SignalFire Cloud service come with a pre-installed SIM card. Customers will require a login to access the SignalFire Cloud server. Please fill out the request form using the button on the right below to set up your company site.

Adding the RANGER to your SignalFire Cloud Group

1. Plug in the battery so the RANGER can connect to the cellular network.
2. Verify that the RANGER is connected to the cellular network by pressing the "CHECKIN" button on the device and observe 3 strobes of the green status light.
3. Login to the SignalFire Cloud with your account login/password
4. From the Home page click "Add Device"
5. Enter the RANGER serial number and click "Claim". The serial number is located on the bottom of the RANGER with a format of "RA" followed by 6 numbers. (e.g. RA123456)
6. A message will be sent to the RANGER to claim it to your group account
7. Within approximately one minute the device will connect to your account, and you will be automatically redirected to the device status page

Technical Support and Contact Information

SignalFire Telemetry
140 Locke Dr., Suite B
Marlborough, MA 01749
(978) 212-2868
support@signal-fire.com

Revision History

Revision	Date	Changes/Updates
1.0	1/6/23	Initial release
1.1	8/2/23	Insert images, Add Active Loop Drawing. Added relay drawings. Added RTD. Added Cloud Setup Page.