

Interface Manual

A2 ANALOG

SignalFire Model: A2-A2D1-XXXX



The SignalFire A2-ANALOG Node has the following features:

- Two 4-20mA/1-5V sensor interfaces, provides 12.0 volts minimum to attached sensors
- One counter/frequency inputs, up to 2kHz. Open drain or pulse input supported
- Reports state of dry contact inputs, open/closed.
- One 32Bit count totalizer
- Low power operation from a 3 "D" cell lithium battery pack (external power from 3.5 to 5.0VDC may be used in place of the battery)
- Sends data to a SignalFire Buffered Modbus Gateway
- AES128bit Encryption
- Remote configuration

Specifications

2

Enclosure Size	7.0" tall × 4.25" wide × 3.0" deep (not including attached antenna)
Power Sources	Internal Lithium battery pack <i>SignalFire Part Number: A2-A2D1-3XD</i> Solar battery system <i>SignalFire Part Number: A2-A2D1-HCSolar</i> <i>DC Powered (10-30V) adapter: A2-A2D1-DCDC</i>
Temperature Rating	-40°C to +80°C
Radio Frequency	902-928MHz ISM Band, FHSS radio, internal antenna
FCC Compliant Radio	FDD ID: W8V-SFTS500 IC: 8373A-SFTS500
Compliance	Class 1, Division 2 Groups A,B,C,D T4 Conforms to: UL 121201:2017 Ed.9+R:01Apr2021 UL 61010-1:2012 Ed.3+R:06Jun2023 UL 61010-2-201:2018 Ed.2+R:08Aug2022 Certified to: CSA C22.2#213:2017 Ed.3+U1;U2;U3 CSA C22.2#61010-1-12:2012 Ed.3+U1;U2;A1;U3 CSA C22.2#61010-2-201:2018 Ed.2

Hazardous Location Certification

3

The A2 is rated Class 1 Division 2 non-incendive when powered by its internal battery pack, High Capacity Solar Module, or its internal DC-DC converter.



WARNING: EXPLOSION HAZARD. DO NOT REMOVE OR REPLACE COMPONENTS UNLESS POWER HAS BEEN DISCONNECTED OR THE AREA IS FREE OF IGNITIBLE CONCENTRATIONS.
AVERTISSEMENT : RISQUE D'EXPLOSION . NE PAS RETIRER OU REMPLACER LES COMPOSANTS QUE L'ALIMENTATION EST DÉBRANCHÉ OU ZONE EST LIBRE DE CONCENTRATIONS IGNITIBLE.



WARNING – EXPLOSION HAZARD Substitution of components may impair suitability for Class I, Division 2

AVERTISSEMENT - RISQUE D'EXPLOSION. La substitution de composants peut rendre ce matériel inacceptable pour les emplacements de classe I, division 2



WARNING – EXPLOSION HAZARD Do not disconnect while circuit is live unless area is known to be nonhazardous

AVERTISSEMENT - RISQUE D'EXPLOSION. Ne débranchez pas lorsque le circuit est en direct , sauf si la zone est connue pour être nonhazardous



WARNING – All wiring methods must be in accordance with the NEC

AVERTISSEMENT - Toutes les méthodes de Essorez doivent être en conformité avec la NEC



WARNING - EXPLOSION HAZARD. Do no remove or replace while circuit is live unless the area is free of ignitable concentrations.

AVERTISSEMENT - RISQUE D'EXPLOSION. Ne pas enlever ou remplacer pendant que le circuit est vivant à moins que la zone soit exempt de concentrations ignitibles.



WARNING – EXPLOSION HAZARD. Do not remove or replace lamps, fuses or plug-in modules (as applicable) unless power has been disconnected or the area is free of ignitable concentrations.

AVERTISSEMENT - RISQUE D'EXPLOSION. Ne retirez ni ne remplacez les lampes, les fusibles ou les modules enfichables (le cas échéant) à moins que l'alimentation ait été coupée ou que la zone soit exempt de concentrations inflammables.

Connections and Components

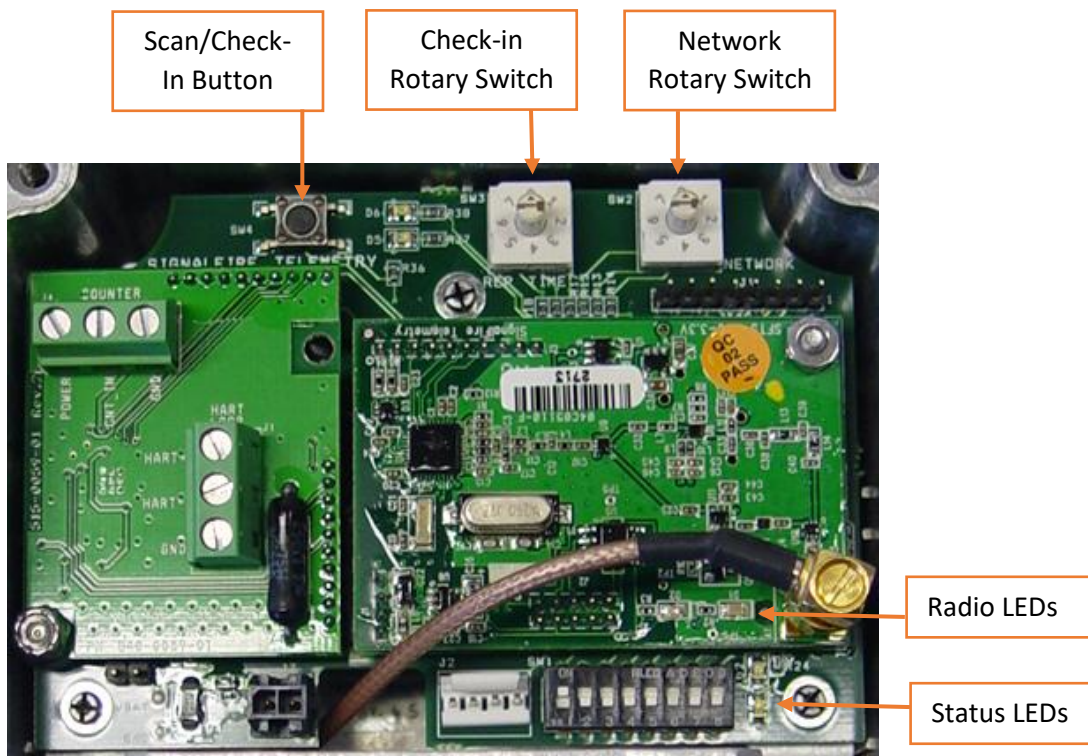

Note: the rotary switches and DIP switch are only installed on legacy devices. All new devices are shipped without the rotary and DIP switch and all configuration is done with the ToolKit.

Radio LEDs

- The Radio TX LED (**green**) flashes each time a radio packet is sent. This LED will blink rapidly while searching for the radio network.
- The Radio RX LED (**red**) blinks on each received radio packet.

Status LEDs

- The Active LED (**green**) will blink at boot up and will blink rapidly when the sensor is being powered.
- The ERROR LED (**red**) will blink to indicate an error condition.

Scan/Checkin Button

- If this button is pressed the A2 will apply power to the sensors for the configured sensor on time and read the analog inputs. The A2 will then send the collected sensor data to the gateway.

Setup

5

The nodes need to be set up for correct operation before being fielded. The configurable items include:

- Network selection (Rotary Switch Legacy)
- Encryption Settings
- Check-in period selection (Rotary Switch Legacy))
- Modbus Slave ID setting
- Sensor on time

Settings are made using the SignalFire Toolkit PC application and a serial programming cable. The Modbus Slave ID can also be set using the DIP switch.

Using the SignalFire Toolkit

The SignalFire Toolkit application can be downloaded at www.signal-fire.com/customer. After installation, launch the software and the main toolkit window will open:

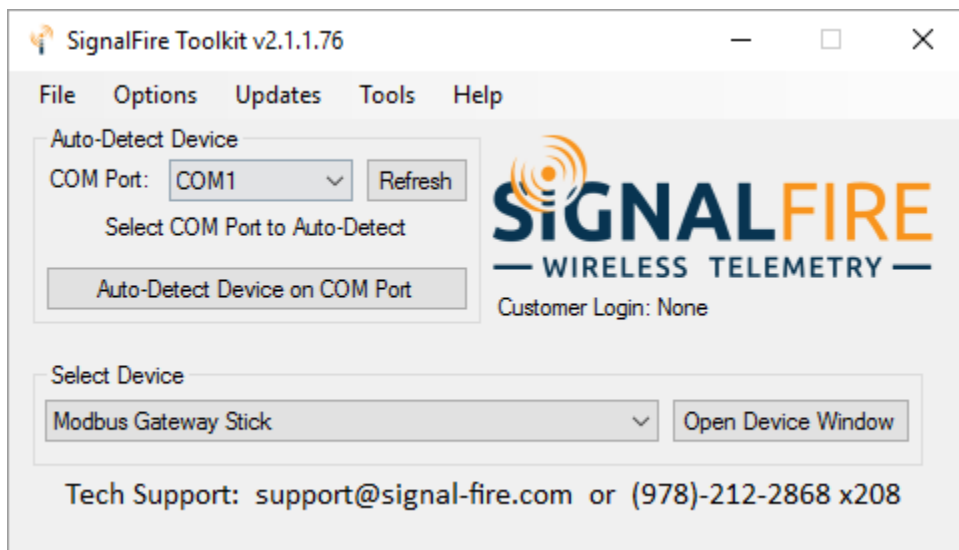

Select the COM port associated with the A2 Node and click "Auto-Detect Device on COM Port." This will open the device configuration window, where all device settings can be configured.

Network Setting

The network is set using the SignalFire Toolkit. The network, network group, and corporate ID/encryption key settings must match those of the gateway for them to communicate.

The network is set using the Network Rotary switch on Legacy A2 units

Radio Network: 3
Radio Network Group: 0
Set

Encryption

Starting with A2 version r72, it is possible to encrypt over-the-air transmissions to prevent tampering. Encryption keys replace the Corporate ID system, so it is important that all devices connected to a Gateway have the same encryption key as well as network and network group number.

To set up a node to use encryption, click the checkbox labeled **Enable Encryption** inside the **Set Corporate ID** box:

Set Corporate ID
 Enable Encryption
Corporate ID: 7
Help
Set

The encryption key box. For more details, click the Help button.

The box will then change into a **Set Encryption Key** box, and it will prompt instead for the encryption key you would like to use. Note that keys may not contain spaces or angle brackets. Enter it and then press **Set**. This will cause the node to drop its network, and only attempt to join networks that use the same encryption key. If you are setting up a new network, you will need to set the encryption key on all of your devices. If you are adding a node to a legacy network, you can simply set the Corporate ID without clicking the Enable Encryption box, and it will remain compatible with the older system.

Set Encryption Key
 Enable Encryption
Key: signalfire
Help
Set

Setting the encryption key.

It is also possible to hide your encryption key so it cannot be read. This is the most secure option, but if you forget your key, there is no way to recover it – you have to reset the key on every device on its network. To enable this option, select **Set Encryption Key Unrecoverable** under the **Settings** menu.

Settings | Updates | Tools | Help
Edit Register Map
Edit Adaptive Reporting Settings
Set Encryption Key Unrecoverable
Digital Input Debounce
Open Close Offline
Connect/Update
4000 [1]
4001-4002
4003 [0]
4003 [1]

Setting the encryption key to be unrecoverable.

Modbus Slave ID

The Modbus Slave ID can be set with the SignalFire Toolkit, or with the DIP switch located on the device legacy devices only).

The DIP switch takes an 8-bit binary input which is converted into a slave ID from 1 to 240. In the picture below switch 1 and 2 are on, which is 00000011 and results in a slave ID of 3. The least significant bit (LSB)

is on the right and is labeled 1 above the row of switches. The A2 must be power cycled after setting the DIP switch. *Note: The DIP switch must be set to 0 (all switches off) in order to set the Slave ID with the SignalFire Toolkit.*

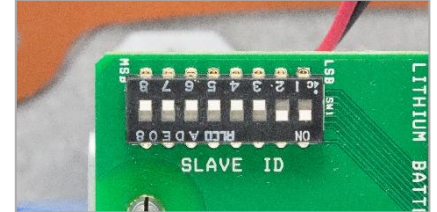

Sensor Settings

The A2-ANALOG Node will supply 12 volts to the sensors. The sensor warm-up time must also be configured. The default is 2 seconds which is used for most pressure and other simple sensors. Radar sensors often require a longer warm-up time. Contact your sensor manufacturer or SignalFire for details.

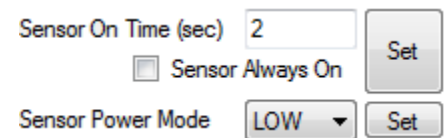

Check-In Interval

The check-in period is set using the SignalFire ToolKit or rotary switch SW1 in the upper right corner of the board for legacy devices. The switch settings are shown in the following table:

Switch Setting	Check-In Period
0	1 min
1	2 min
2	4.5 min
3	10 min
4	30 min
5	1 hr
6	5 sec
7	15 sec

The default setting is 2 for a check-in period of 4.5 minutes.

Note: Settings 6 and 7 should only be used for testing or a non-battery pack powered node as they will have a high power draw.

Alarm Thresholds

The A2 Analog optionally has alarm threshold registers that when configured will indicate if the most recent analog reading is above or below the configured threshold. To use the alarm thresholds the analog input must be scaled as the alarm thresholds operate from the scaled values. For example, if a 4-20mA, 0-100psi sensor is used the scaling would be configured for 0 to 100. If the corresponding Alarm High threshold is set for 75, any reading above 75 will cause the Alarm High Register to read 1.

Sensor Connections

4-20mA Sensor Connection

Any 4-20mA sensor may be connected to the system using the screw terminal connectors on the connector daughterboard. 4-20mA sensors use two of the three terminals as shown in the following diagram:

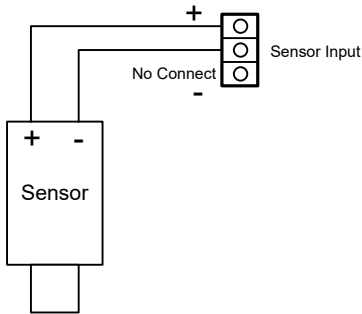

Jumpers – Each channel has a set of 3 jumpers associated with it. The two jumpers labeled “4-20mA” need to be in place for 4-20mA operation (and the third one labeled “VOLTS” needs to be un-installed).

The system will supply a minimum of 12 Volts to the sensors for 2 seconds (by default) and then read the Analog data from each sensor.

1-5V Sensor Connection

A voltage output sensor may be connected to the sensor interface board. This type of sensor uses all three of the connections for powering and sensing as shown in the following diagram:

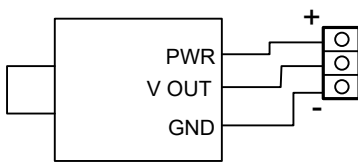

Jumpers – Each channel has a set of 3 jumpers associated with it. The jumper labeled “VOLTS” need to be in place for voltage sensor operation. The two positions labeled “4-20mA” must be un-installed.

The system will supply a minimum of 12 Volts to the sensors for 2 seconds (by default) and then read the Analog data from each sensor.

Digital Input

The counter input may be either open collector type (sinking ground), dry contact inputs, or voltage pulse (up to 15V) type. The input can count up to 2000 Hz.

The counter input may be connected to the board as shown in the following diagrams:

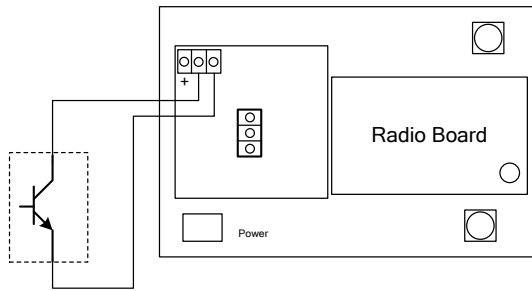

Open Collector Connection

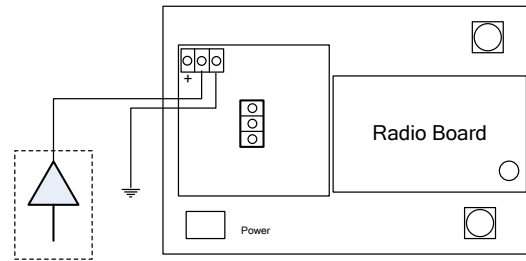

Voltage Pulse Connection

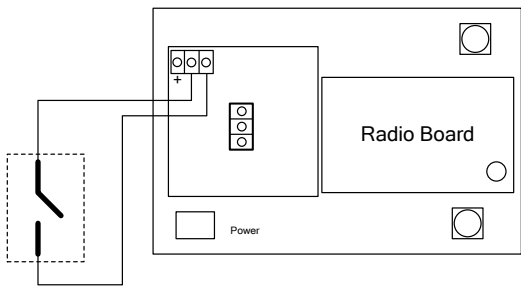

Dry Contact Connection

The count accumulates and the current count is stored into non-volatile memory. If the system is reset the counts will revert to the last stored value from non-volatile memory.

The system also reports the state of the contact closure input at the time of check-in.

Digital Input Debounce

In cases where it is desired to accurately totalize digital input counts it may be necessary to enable the digital input debounce timer. The debounce timer is useful when dealing with dry contacts that may otherwise produce extra counts when they close. To enable the digital debounce, open the configuration window for the node in the SignalFire Toolkit and select **Digital Input Debounce** from the **Settings** menu. A typical value for a dry contact would be 100mS. Any extra counts due to contact bounce within the debounce time setting will be ignored.

Remote Modbus Register Mapping

10

The A2-ANALOG sends data to a SignalFire Telemetry Modbus Gateway. The data that is sent to the gateway is available at the gateway in registers where it can then be read by a Modbus RTU. Consequently, the node needs to have a unique (to the network it is in) Modbus slave ID which the gateway will use to store its unique data.

Register Map

Register Number	Register Address (Offset)	Description
41002	1001	A/D Loop A (12 bit A/D counts value) (LEGACY OPERATION)
41003	1002	A/D Loop B (12 bit A/D counts value) (LEGACY OPERATION)
41004	1003	Digital Input state (1=closed, 0=open)
41005-41006	1004-1005	32-bit Int Hardware counter, 1004=high word
41007	1006	Average frequency over the last check-in period times 10
41007	1006	Average frequency over the last check-in period times 10
41008	1007	Loop A current in μA (1 μA resolution)
41009	1008	Loop B current in μA (1 μA resolution)
41010	1009	Loop A voltage in mV (1mV resolution)
41011	1010	Loop B voltage in mV (1mV resolution)
41012	1011	Ave. counts per minute over the check-in period times 10
41013	1012	Frequency over 2 seconds at check-in time times 10
41026	1025	Loop A with custom scaling (32bit Float High Byte)
41027	1026	Loop A with custom scaling (32bit Float Low Byte)
41028	1027	Loop B with custom scaling (32bit Float High Byte)
41029	1028	Loop B with custom scaling (32bit Float Low Byte)
41030	1029	Alarm A High Notification
41031	1030	Alarm A Low Notification
41032	1031	Alarm B High Notification
41033	1032	Alarm B Low Notification
49988	9987 or 65524	Major revision number for the mainboard
49989	9988 or 65525	Minor revision number for the mainboard
49990	9989 or 65526	Major revision number for the radio
49991	9990 or 65527	Minor revision number for the radio
49992	9991 or 65528	High 16 bits of SFTS node address
49993	9992 or 65529	Low 16 bits of SFTS node address (the radio ID)
49994	9993 or 65530	Slave ID readback
49995	9994 or 65531	Received signal strength of last packet from the slave
49996	9995 or 65532	Battery voltage of the Modbus client, in millivolts
49997	9996 or 65533	Minutes until this slave will time out, unless new data is received
49998	9997 or 65534	Number of registers cached for this slave device
49999	9998 or 65535	Remote device type. (32 for A2-ANALOG)

Registers 1001 and 1002 contain a legacy 12bit representation of the measured A/D values as follows:
365.7 counts / Volt or 83.4 counts / mA

Modbus Registers

Every check-in period, the sensor(s) are read and data is sent to the gateway. The gateway will save the data under the set Modbus ID in 16-bit registers

11

Configuration / Debug

Debug and configuration information is available if a connection is made via the debug port on the main board. A USB converter cable (available from SignalFire) must be used for this interface.

Debug and configuration may be done using the SignalFire Toolkit PC application.

Product Disposal Information

12

To ensure environmental safety and compliance, please follow these disposal instructions for the product and its components:

Lithium Primary Battery:

This product contains lithium primary batteries, which must be removed before disposal. Lithium batteries must be recycled through specialized facilities due to their fire risk. Do not place batteries in regular trash.

Electronic Components:

This product contains electronics that must be recycled through approved e-waste recycling programs. Electronics can contain harmful materials and should be prevented from entering landfills. Do not place electronics in regular trash.

Metal Parts:

Any metal components can be separated and recycled through your local metal recycling facility.

Packaging Materials:

Recycle or reuse packaging materials such as cardboard or plastics, following local recycling guidelines.

For local disposal sites refer to:

- [Call2Recycle](#) (USA, Canada)
- [Earth911](#) (USA, Canada)
- [SERI](#) (International)

In the USA or more information, visit:

- [EPA's battery disposal guide](#)
- [EPA's electronics recycling page](#)

By following these guidelines, you help reduce waste and support environmental sustainability.

Technical Support and Contact Information

SignalFire Telemetry
140 Locke Dr, Suite B
Marlborough, MA 01752
(978) 212-2868
support@signal-fire.com

Revision History

Revision	Date	Changes/Updates
9.3	9/12/17	Updated layout. Added section on encryption, updated register map
9.4	1/28/21	Address updated
9.5	5/1/23	Add warnings page
9.5.2	7/21/23	Update Specifications