

DIN GATEWAY V2

Wireless 900MHz Gateway with Integrated I/O

- CONNECTIVITY TO WIRELESS & WIRED SENSORS
- INTEGRATED ETHERNET
- LONG RANGE OF 3+ MILES
- BUILT-IN AUTOMATION
- CLASS 1 DIVISION 2 CERTIFIED



FEATURES

- Modbus interface RS485 RTU or Modbus TCP
- Long range: 3+ miles
- Wired inputs/outputs: 2DI, 2DO, 3AI
- Manages outbound communications
- Low power consumption
- External high-gain omnidirectional antenna
- Supports wireless configuration of remote nodes and HART® devices via PACTware®, Fieldcare, or Radar Master
- Automatically configures as star or mesh network
- Easy to program internal logic for control applications

DIMENSIONS

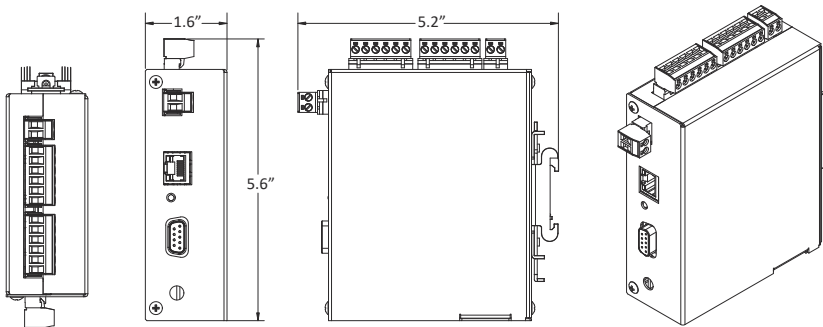

WIRELESS AND WIRED SENSOR CONNECTIVITY

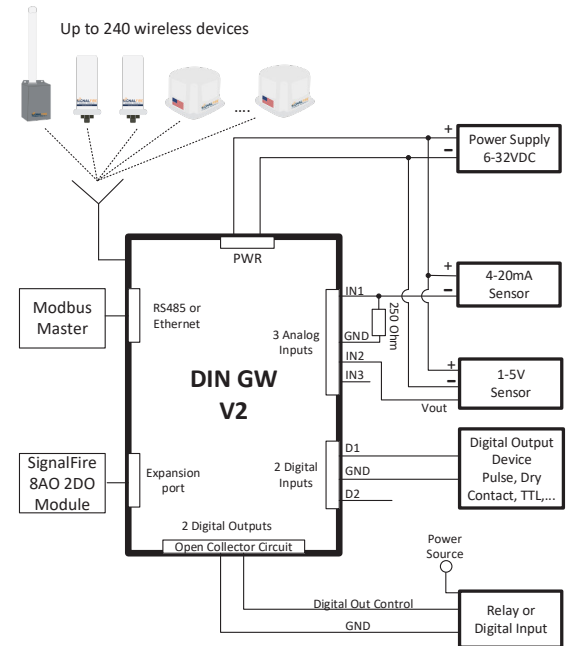

DIN GATEWAY V2

Wireless 900MHz Gateway with Integrated I/O

TECHNICAL SPECIFICATIONS

Operating Temp

-40°F to 185°F (-40°C to 85°C)

Humidity

0% – 95% non-condensing

Power Requirements

6-36 VDC

Average Power Consumption

Modbus RS485 Version

25mA @ 12Vdc

16mA @ 24Vdc

Modbus TCP

85mA @ 12Vdc

50mA @ 24Vdc

Data Interface

RS-485 Modbus RTU, or Modbus-TCP, RS 232 for configuration. All readings are converted to Modbus registers and stored in the gateway.

Radio Power

500 mW

Antenna Type

Omnidirectional

Antenna Gain

- Panel Mounted: +2dBi
- W Pole Type: +5dBi

Receive Sensitivity

-105 dB

Frequency

902-928 MHz license-free ISM band compliant with FCC Part 15 and Industry Canada

Range

Up to 3 miles

Enclosure

- Powder coated metal
- Metal DIN connector

End Nodes

Up to 240 SignalFire end nodes

Safety Rating

Nonincendive, Class 1 Division 2 Groups C and D, T5

Internal Diagnostics

Line voltage, signal strength, error conditions, internal event logging, Modbus communications

Inputs & Outputs

- Two (2) digital input
- Two (2) digital output (open collector pull down)
- Three (3) 1-5Vdc / 4-20mA analog input
- Expansion port for SignalFire Gateway output module (8 analog outputs / 2 relay outputs)

Weight

1.2 lbs (0.5kg)

DIN GATEWAY V2

Wireless 900MHz Gateway with Integrated I/O

HOW TO ORDER

